



DIN ISO 7388-1

A - AD - AD/B

Werkzeugaufnahmen

Toolholders

Porte-outils

Takım Tutucular

INHALTSVERZEICHNIS / INDEX	Seite / Page
Spannzangenfutter - Collet chuck Mandrin à pincés - Pens başlığı	1.05 - 1.11
Ausrichtbares Spannfutter - Adjustable tool holder Tige de réglage - Hassas ayarlanabilir pens tutucu	1.12
Kraftspannfutter - Power milling chuck Mandrin de fraisage - Bilyalı pens tutucu	1.13
Fräseraufnahmen - End mill holder Porte-fraises - Veldon tutucu	1.14 - 1.23
Spannzangenfutter - Pull type collet chuck Mandrin de serrage de précision - Çektirmeli pens başlığı	1.24 - 1.26
Morsekegel Aufnahmen - Morse taper adapter Douilles intermédiaires - Mors adaptörü	1.27
Zwischenhülsen mit Anzugsgewinde - Morse taper adapter Douilles intermédiaires - Mors adaptörü çektirmeli	1.28
Reduzierungen - Reduction sleeves Douilles de réduction - Redüksiyon	1.28
Kombi-Aufsteckfräserdorne - Combi shell mill holder Porte-fraises à double usage pour fraises - Kombine malafa	1.29 - 1.32
Quernut-Aufsteckdorne - Shell mill holder Porte-fraises à surfacer - Alın kamalı malafa	1.33 - 1.36
Aufschraubfräser - Milling cutter arbors Axess coupeur fraisage - Vidalı takım tutucu	1.37 - 1.39
Bohrerhalter E1 - Boring holder E1 Porte foret E1 - Takma uçlu drill tutucu E1	1.40
Bohrfutteraufnahme - Drill chuck Arbre pour mandrin de perçage - Mandren malafası	1.40
NC-Bohrfutter - NC - Drill chuck Mandrin de perçage - NC mandren malafası	1.41
Gewindeschneidfutter - Quick change tapping chuck Appareil à tarauder - Kılavuz çekme başlığı	1.42
Rohlinge - Blanks Barre d'alésage - Özel takım yapma amaçlı yarı mamul	1.43
Kontrolldorne - Test arbors Mandrin de contrôle - Kontrol mastarı	1.43
Schrumpffutter - Shrink chuck Mandrin de frettage - Isıtmalı takım tutucu	1.44 - 1.48
Hydro - Dehnspannfutter - Hydraulic expansion chuck Mandrin expansibles - Hidrolik takım tutucu	1.49 - 1.52



Mit EROGLU erhalten Sie auch Semi-Standard – in der gleichen Qualität!

With EROGLU you receive semi-standard, too – within the same quality!

Avec EROGLU vous recevez aussi semi-standard – avec la même qualité!

Özel ürün seçenekleri ile EROĞLU kalitesi hep sizinle...

. ERP

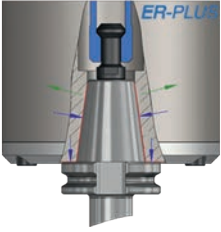

SK Halter können als ER-PLUS (Doppelkontakt) gefertigt werden
(Beispiel Bestellnummer: 402.02.10.63.ERP)

SK products can be produced as ER-PLUS (Dual face contact)
(Example order code no: 402.02.10.63.ERP)

Mandrins SK peut être fabrique comme version ER-PLUS (double contact)
(Exemple commande no: 402.02.10.63.ERP)

Tüm SK ürünler ER-PLUS (Çift yüzey temaslı) olarak üretilebilir.
(Örnek sip. Nr. : 402.02.10.63.ERP)

. ON



Alle SK30 Aufnahmen auf Seite 1.06 - 1.14 - 1.29 - 1.44 können für
Holzbearbeitungsmaschinen als Typ "ON" (ohne Mitnehmernuten und ohne
Positionierungskerbe) bestellt werden. (Beispiel Bestellnummer: 302.02.10.70.ON)

All SK30 chucks at page 1.06 - 1.14 - 1.29 - 1.44 can be ordered for wooden
machines as type "ON" (without driving grooves and without positioning mark).
(Example order code no: 302.02.10.70.ON)

Tous les mandrins SK30 à la page 1.06 - 1.14 - 1.29 - 1.44 peuvent également être
commandés pour les machines à bois de type "ON" (sans rainure de clavette et
sans marquage de positionnement). (Exemple commande no: 302.02.10.70.ON)

Sayfa numaraları belirtilen takım tutucular için SK30 kama kanalsız üretilebilir.
Sayfa 1.06 - 1.14 - 1.29 - 1.44 (Örnek sip. Nr. : 302.02.10.70.ON)

. G2.5 x ...

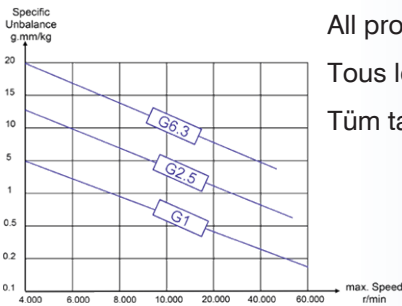

Alle Artikel können mit dem angegebenen Maximalwert feingewuchtet werden.

All products can be produced in the specified maximum balance value.

Tous les articles peuvent être spécifiés avec le maximum de précision équilibrée.

Tüm takım tutucular belirlenen max. balans değerlerinde üretilebilir.

. CAT



Alle Werkzeugaufnahmen können auch gemäß CAT Norm gefertigt werden.

All tool holders can be produced in accordance with CAT ASME B5.5 (ANSI B5.5)

Tous les porte-outils peuvent être fabriqués aussi selon le standard CAT.

Tüm takım tutucular CAT ASME B5.5 (ANSI B5.5) normuna uygun olarak
üretilebilir.



ER-PLUS Doppelkontakt

ER-PLUS Dual face contact

ER-PLUS double contact

ER-PLUS Çift yüzey teması

Standard Werkzeug-System
Standard Tooling System
système d'outils standard
Standart Takım sistemi
Abstand / Distance / Distance / Mesafe

ER-PLUS Werkzeug-System
ER-PLUS Tooling System
ER-PLUS système d'outils
ER-PLUS Takım Sistemi
Kontakt / Contact / Contact / Teması

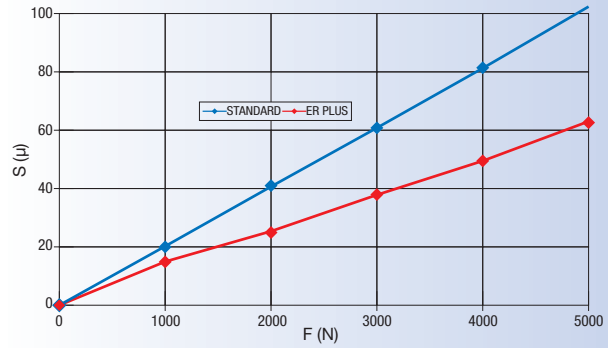
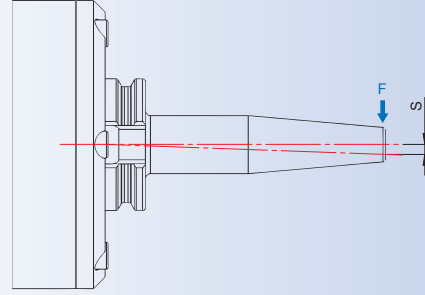
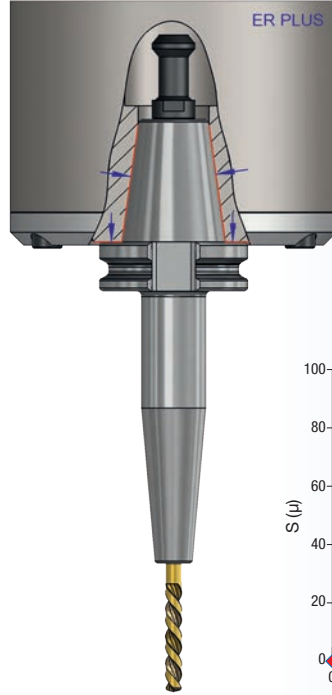
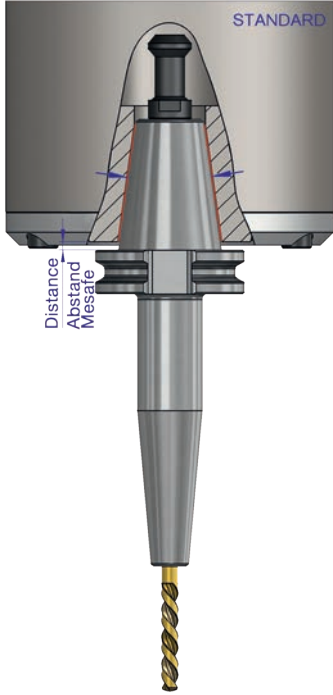

Der Unterschied des ER-PLUS Systems zur konventionellen Schnittstelle, ist eine doppelte Kontaktfläche: am Kegel und gleichzeitig am Werkzeugflansch. Dies erlaubt eine höhere Radialsteifigkeit.

The differences between standard contact face to ER-PLUS system, is a dual contact face: by shank and also flange face. This allows a higher radial rigidity.

La différence du système ER-PLUS d'interface est un contact double: au cône et bride. C'est rendre possible une plus haute rigidité radiale.

Standart takım sistemi ile ER-PLUS takım sistemi arasındaki farklılık, ER-PLUS sisteminde konikte ve alında çift temas yüzeyi sağlamaktır. Bu takımda yüksek radyal rijitlik sağlar.

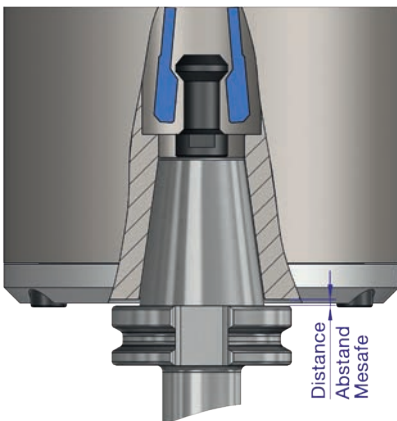

Vor dem Einspannen
Before clamping
Avant tendre
Çektirmeden önce

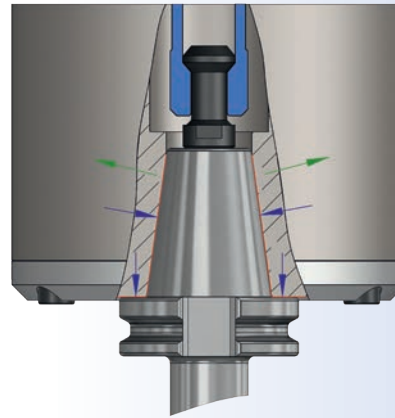

Nach dem Einspannen
After clamping
Après tendre
Çektirmeden sonra

Beispiel Bestellnummer : 403.25.06.80.ERP
Example order code no : 403.25.06.80.ERP
Exemple commande no : 403.25.06.80.ERP
Örnek sipariş numarası : 403.25.06.80.ERP



Werkzeugaufnahmen

SK DIN 69871 (DIN ISO 7388-1) AD

Toolholders

Porte-outils

Merkezden Soğutmalı
Konik Şaft Ölçüleri

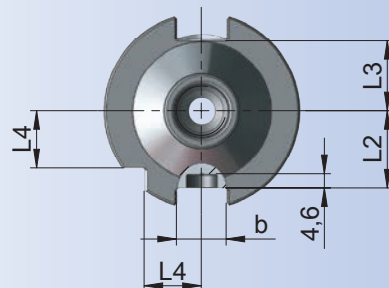
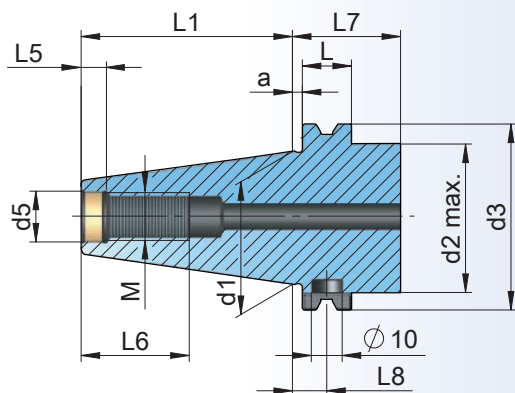

Werkzeugaufnahmen

SK DIN 69871 (DIN ISO 7388-1) AD/B

Toolholders

Porte-outils

Merkezden ve
(B) Alından Soğutmalı
Konik Şaft Ölçüleri

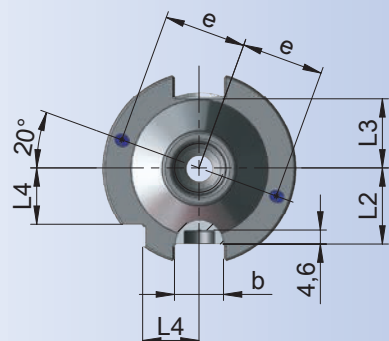
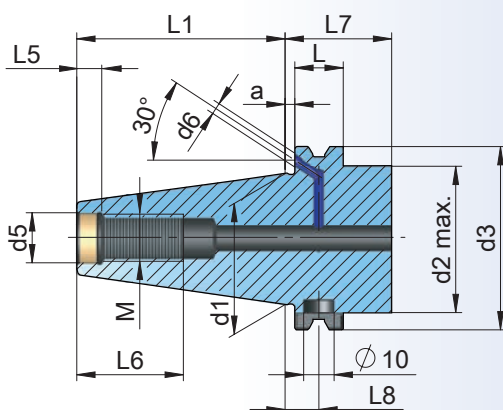

Werkzeugaufnahmen SK ERPLUS

SK DIN 69871 (DIN ISO 7388-1) AD

Toolholders SK ERPLUS

Porte-outils SK ERPLUS

Merkezden Soğutmalı
Konik Şaft Ölçüleri

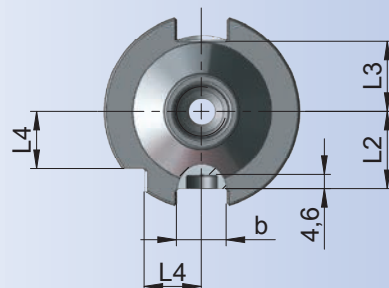
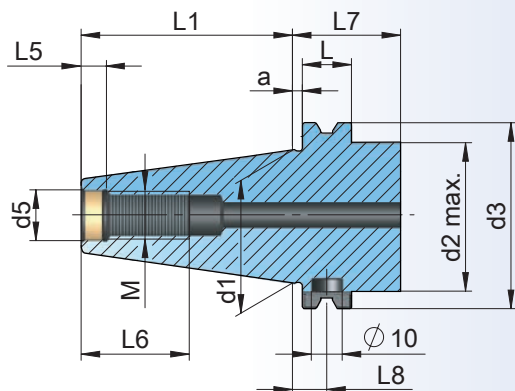

Werkzeugaufnahmen SK ERPLUS

SK DIN 69871 (DIN ISO 7388-1) AD/B

Toolholders SK ERPLUS

Porte-outils SK ERPLUS

Merkezden ve
(B) Alından Soğutmalı
Konik Şaft Ölçüleri

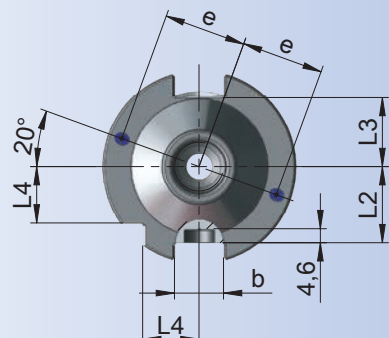
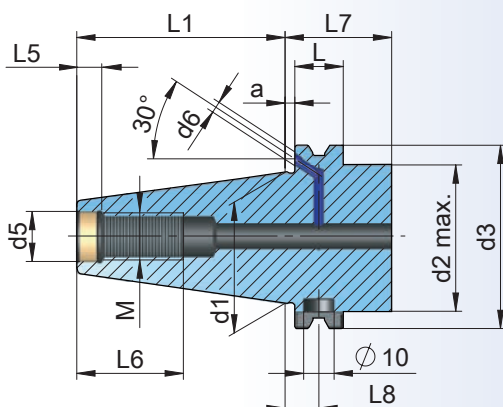



SK	FORM	d1	a	M	L6	d3	L	d2 max.	L7	L1	d5	L5	b	L2	L3	L4	L8	d6	e
SK 30	AD	31,75	3,2	M12	24	50,00	15,9	45	35	47,80	13	5,5	16,1	18,8	16,3	15,0	11,1	-	-
SK 40	AD	44,45	3,2	M16	32	63,55	15,9	50	35	68,40	17	8,2	16,1	25,0	22,7	18,5	11,1	-	-
SK 40	AD/B	44,45	3,2	M16	32	63,55	15,9	50	35	68,40	17	8,2	16,1	25,0	22,7	18,5	11,1	4	27
SK 40-ERP	AD	44,45	1,0	M16	32	63,55	18,1	50	35	68,40	17	8,2	16,1	25,0	22,7	18,5	11,1	-	-
SK 40-ERP	AD/B	44,45	1,0	M16	32	63,55	18,1	50	35	68,40	17	8,2	16,1	25,0	22,7	18,5	11,1	4	27
SK 50	AD	69,85	3,2	M24	47	97,50	15,9	80	35	101,75	25	11,5	25,7	37,7	35,5	30,0	11,1	-	-
SK 50	AD/B	69,85	3,2	M24	47	97,50	15,9	80	35	101,75	25	11,5	25,7	37,7	35,5	30,0	11,1	6	42
SK 50-ERP	AD	69,85	1,5	M24	47	97,50	17,6	80	35	101,75	25	11,5	25,7	37,7	35,5	30,0	11,1	-	-
SK 50-ERP	AD/B	69,85	1,5	M24	47	97,50	17,6	80	35	101,75	25	11,5	25,7	37,7	35,5	30,0	11,1	6	42

Werkstoff : Legierter Einsatzstahl mit einer Zugfestigkeit im Kern von min. 950 N/mm²

Ausführung : Einsatzgehärtet HRC 58 ± 2 Härtetiefe 0,6 mm + 0,2 mm, brüniert

Genauigkeit : Kegelwinkel-Toleranzqualität AT 3 nach DIN 2080
Oberflächenrauigkeit des Kegels Ra 0,2

Chip : Bohrung für Datenträger DIN 69873 im Bund.

Material : Case hardened steel, tensile strength in the core min. 950 N/mm²

Execution : Case hardened HRC 58 ± 2 Depth of case 0,6 mm + 0,2 mm,
black-finish

Accuracy : Cone angle AT 3 according DIN 2080
Surface roughness of cone Ra 0,2

Chip hole : Bore for data carrier DIN 69873 in collar.

Matière : Châssis d'allié en acier de cémentation. Résistance à la traction dans le noyau
de min 950 N/mm²

Exécution : Cementé HRC 58 ± 2 Epaisseur de cémentation 0,6 mm + 0,2 mm
Bruni

Précision : Qualité de finition pour l'angle des cône AT 3 suivant DIN 2080
Rugosité en surface du cône Ra 0,2

Puce : Pergage pour support de données DIN 69873 dans la collerette.

Malzeme : Alaşımlı semente çeliği çekme mukavemeti min. 950 N/mm²

Teknik özelliği : Sertlik HRC 58 ± 2 sertlik derinliği 0,6 mm + 0,2 mm, karartılmış

Hassasiyeti : Konik açı tolerans kalitesi DIN 2080 normuna göre AT 3
Konik yüzey kalitesi Ra 0,2

Çip deliği : Takım bilgilerini saklamak için flanşta DIN 69873 özel çip deliği.



Werkzeugaufnahmen

CAT ASME B 5.50 (ANSI B 5.50) AD

Toolholders

Porte-outils

Merkezden Soğutmalı
Konik Şaft Ölçüleri

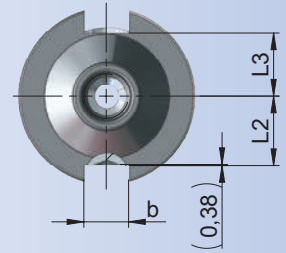
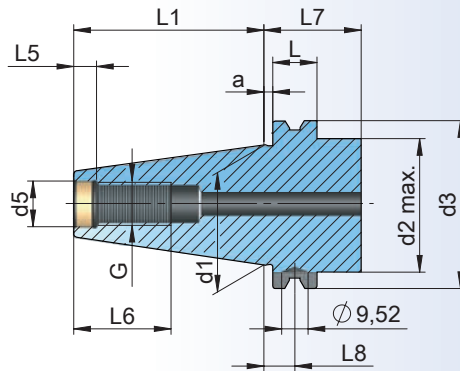

Werkzeugaufnahmen

CAT ASME B 5.50 (ANSI B 5.50) AD/B

Toolholders

Porte-outils

Merkezden ve
(B) Alından Soğutmalı
Konik Şaft Ölçüleri

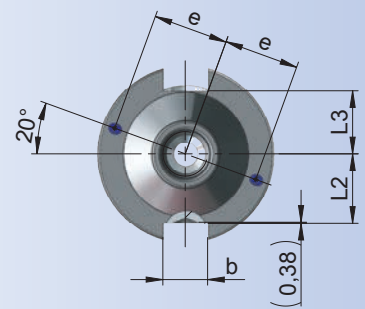
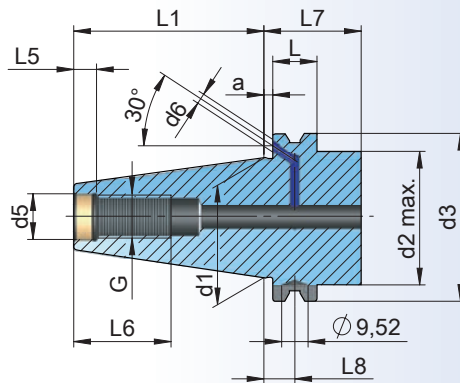

CAT	FORM	d1	a	G	L6	d3	L	d2 max.	L7	L1	d5	L5	b	L2	L3	L8	d6	e
CAT 40	AD	1,75"	0,125"	5/8"x11	1,12"	2,5"	0,625"	1,75"	1,38"	2,687"	0,641"	0,188"	0,645"	0,985"	0,89"	0,438"	-	-
CAT 40	AD/B	1,75"	0,125"	5/8"x11	1,12"	2,5"	0,625"	1,75"	1,38"	2,687"	0,641"	0,188"	0,645"	0,985"	0,89"	0,438"	0,157"	1,062"
CAT 50	AD	2,75"	0,125"	1"x8	1,75"	3,875"	0,625"	2,75"	1,38"	4"	1,031"	0,25"	1,02"	1,485"	1,39"	0,438"	-	-
CAT 50	AD/B	2,75"	0,125"	1"x8	1,75"	3,875"	0,625"	2,75"	1,38"	4"	1,031"	0,25"	1,02"	1,485"	1,39"	0,438"	0,236"	1,654"

Werkstoff : Legierter Einsatzstahl mit einer Zugfestigkeit im Kern von min. 950 N/mm²

Ausführung : Einsatzgehärtet HRC 58 ± 2 Härtetiefe 0,6 mm + 0,2 mm, brüniert

Genauigkeit : Kegelwinkel-Toleranzqualität AT 3 nach DIN 2080
Oberflächenrauigkeit des Kegels Ra 0,2

Material : Case hardened steel, tensile strength in the core min. 950 N/mm²

Execution : Case hardened HRC 58 ± 2 Depth of case 0,6 mm + 0,2 mm, black-finish

Accuracy : Cone angle AT 3 according DIN 2080
Surface roughness of cone Ra 0,2

Matière : Châssis d'allié en acier de cémentation. Résistance à la traction dans le noyau de min 950 N/mm²

Exécution : Cémenté HRC 58 ± 2 Epaisseur de cémentation 0,6 mm + 0,2 mm Bruni

Précision : Qualité de finition pour l'angle des cônes AT 3 suivant DIN 2080
Rugosité en surface du cône Ra 0,2

Malzeme : Alaşımli semente çeliği çekme mukavemeti min. 950 N/mm²

Teknik özelliği : Sertlik HRC 58 ± 2 sertlik derinliği 0,6 mm + 0,2 mm, karartılmış

Hassasiyeti : Konik açı tolerans kalitesi DIN 2080 normuna göre AT 3
Konik yüzey kalitesi Ra 0,2



Spannfutter OZ

Collet chucks OZ

Mandrin à pinces OZ

Pens başlığı OZ

DIN
69871

AD
AD/B

DIN
6391

DIN ISO
10897

HRC
58±2



STANDARD
G 2.5
25.000
min⁻¹
U ≤ 1gmm

SPECIAL
max.
G 2.5
50.000
min⁻¹
U ≤ 1gmm



Bestell-Nr. Order Nr. Reference Sipariş Nr.	SK	Form	Abmessung Size Dimension Cinsi	Spannbereich Capacity Capacité Kapasite	A		L2	Kg	Euro
					D	D			
302.01.16.60	SK 30	AD	OZ 16	415 E (2 - 16)	60	43	51	0,58	
302.01.25.80	SK 30	AD	OZ 25	462 E (2 - 25)	80	60	61,5	0,97	
402.01.16.70	SK 40	AD	OZ 16	415 E (2 - 16)	70	43	51	1,13	
403.01.16.70	SK 40	AD/B	OZ 16	415 E (2 - 16)	70	43	51	1,13	
402.01.16.100	SK 40	AD	OZ 16	415 E (2 - 16)	100	43	51	1,44	
403.01.16.100	SK 40	AD/B	OZ 16	415 E (2 - 16)	100	43	51	1,44	
402.01.25.70	SK 40	AD	OZ 25	462 E (2 - 25)	70	60	64	1,30	
403.01.25.70	SK 40	AD/B	OZ 25	462 E (2 - 25)	70	60	64	1,30	
402.01.25.100	SK 40	AD	OZ 25	462 E (2 - 25)	100	60	64	1,69	
403.01.25.100	SK 40	AD/B	OZ 25	462 E (2 - 25)	100	60	64	1,69	
402.01.32.90	SK 40	AD	OZ 32	467 E (4 - 32)	90	72	74	1,77	
403.01.32.90	SK 40	AD/B	OZ 32	467 E (4 - 32)	90	72	74	1,77	
502.01.16.70	SK 50	AD	OZ 16	415 E (2 - 16)	70	43	51	2,90	
503.01.16.70	SK 50	AD/B	OZ 16	415 E (2 - 16)	70	43	71	2,90	
502.01.25.70	SK 50	AD	OZ 25	462 E (2 - 25)	70	60	64	3,20	
503.01.25.70	SK 50	AD/B	OZ 25	462 E (2 - 25)	70	60	68	3,20	
502.01.32.80	SK 50	AD	OZ 32	467 E (4 - 32)	80	72	74	3,64	
503.01.32.80	SK 50	AD/B	OZ 32	467 E (4 - 32)	80	72	77	3,64	
502.01.32.100	SK 50	AD	OZ 32	467 E (4 - 32)	100	72	74	4,26	
503.01.32.100	SK 50	AD/B	OZ 32	467 E (4 - 32)	100	72	74	4,26	

FORM AD

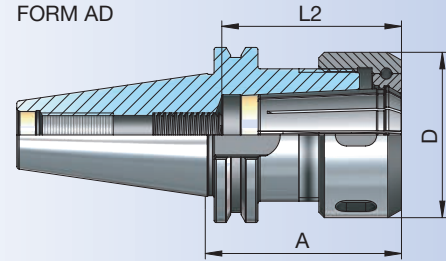

FORM AD/B

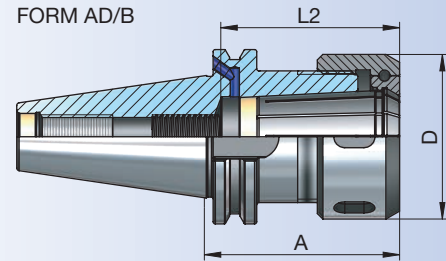

Zubehör / Accessories / Accessoires / Yedekler



Spannzangen OZ
Collets OZ
Pincés de serrage OZ
Pens başlığı OZ



Spannmutter OZ
Clamping nuts OZ
Écrou de serrage OZ
Pens kapağı OZ



Hakenschlüssel
Wrench
Clé à ergot
E tipi ay anahtar



Spannfutter ER

Collet chucks ER

Mandrin à pinces ER

Pens başlığı ER

DIN
69871

AD
AD/B

DIN ISO
15488

HRC
58±2



STANDARD
G 2.5
25.000
 min^{-1}
 $U \leq 1\text{gmm}$

SPECIAL
max.
G 2.5
50.000
 min^{-1}
 $U \leq 1\text{gmm}$



Bestell-Nr. Order Nr. Reference Sipariş Nr.	SK	Form	Spannbereich Capacity Capacité Kapasite	A	D	D1	L1	L2	Kg	Euro
302.02.10.70	SK 30	AD	ER16 (1 - 10)	70	28	-	-	32	0,54	
302.02.10.100	SK 30	AD	ER16 (1 - 10)	100	28	-	-	32	0,67	
302.02.16.70	SK 30	AD	ER25 (2 - 16)	70	42	-	-	42	0,68	
302.02.16.100	SK 30	AD	ER25 (2 - 16)	100	42	-	-	42	0,99	
302.02.20.70	SK 30	AD	ER32 (2 - 20)	70	50	-	-	48	0,67	
302.02.20.100	SK 30	AD	ER32 (2 - 20)	100	50	-	-	48	0,95	
*302.02.20.50.ON	SK 30	AD	ER32 (2 - 20)	50	50	-	-	48	0,52	
*302.02.20.70.ON	SK 30	AD	ER32 (2 - 20)	70	50	-	-	48	0,70	
302.02.26.70	SK 30	AD	ER40 (3 - 26)	70	63	-	-	55	0,82	

FORM AD

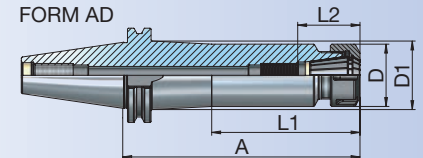

FORM AD/B

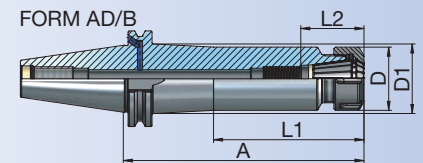

ER 16

new

new

new

new

402.02.10.63	SK 40	AD	ER16 (1 - 10)	63	28	-	-	32	0,94	
403.02.10.63	SK 40	AD/B	ER16 (1 - 10)	63	28	-	-	32	0,93	
402.02.10.100	SK 40	AD	ER16 (1 - 10)	100	28	-	-	32	1,09	
403.02.10.100	SK 40	AD/B	ER16 (1 - 10)	100	28	-	-	32	1,08	
402.02.10.130	SK 40	AD	ER16 (1 - 10)	130	28	-	-	32	1,20	
403.02.10.130	SK 40	AD/B	ER16 (1 - 10)	130	28	-	-	32	1,20	
402.02.10.160	SK 40	AD	ER16 (1 - 10)	160	28	32	98	32	1,36	
403.02.10.160	SK 40	AD/B	ER16 (1 - 10)	160	28	32	98	32	1,35	
403.02.10.200	SK 40	AD/B	ER16 (1 - 10)	200	28	34	120	32	1,55	
new 403.02.13.70	SK 40	AD/B	ER20 (1 - 13)	70	34	-	-	39,5	1,03	
new 403.02.13.100	SK 40	AD/B	ER20 (1 - 13)	100	34	-	-	39,5	1,21	
new 403.02.13.130	SK 40	AD/B	ER20 (1 - 13)	130	34	-	-	39,5	1,40	
new 403.02.13.160	SK 40	AD/B	ER20 (1 - 13)	160	34	38	99,5	39,5	1,62	
402.02.16.60	SK 40	AD	ER25 (2 - 16)	60	42	-	-	42	1,02	
403.02.16.60	SK 40	AD/B	ER25 (2 - 16)	60	42	-	-	52	1,01	
402.02.16.100	SK 40	AD	ER25 (2 - 16)	100	42	-	-	42	1,42	
403.02.16.100	SK 40	AD/B	ER25 (2 - 16)	100	42	-	-	42	1,41	
402.02.16.130	SK 40	AD	ER25 (2 - 16)	130	42	-	-	42	1,72	
403.02.16.130	SK 40	AD/B	ER25 (2 - 16)	130	42	-	-	42	1,71	
402.02.16.160	SK 40	AD	ER25 (2 - 16)	160	42	46,5	100	42	2,06	
403.02.16.160	SK 40	AD/B	ER25 (2 - 16)	160	42	46,5	100	42	2,05	
403.02.16.200	SK 40	AD/B	ER25 (2 - 16)	200	42	48,5	120	42	2,51	

* Die Aufnahmen für die Holzbearbeitung werden ohne Mitnehmernuten und ohne Positionierungskerbe hergestellt.

* The holders for the woodworking is produced without driving grooves and without positioning mark

* L'outils pour le travail du bois sont produits sans rainures de brides et sans marquage de positionnement.

* Ağaç işleme tezgahları için kama kanalsız üretilmektedir .

Zubehör / Accessories / Accessoires / Yedekler

DIN ISO
15488



Spannzangen System ER
Collets System ER
Pincés de serrage System ER
Pens ER

DIN ISO
15488



Spannmutter ER
Clamping nuts ER
Écrou de serrage ER
Pens kapağı ER



10.48

Spannschlüssel für ER
Wrench ER
Clé de serrage ER
Anahtar ER

i

11.01



Spannfutter ER

Collet chucks ER

Mandrin à pinces ER

Pens başlığı ER

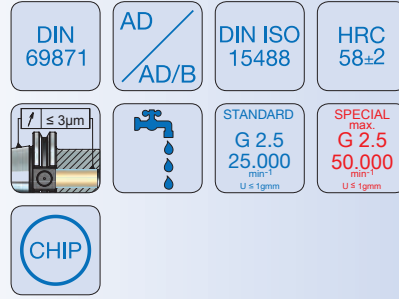

Bestell-Nr. Order Nr. Reference Sipariş Nr.	SK	Form	Spannbereich Capacity Capacité Kapasite	A	D	D1	L1	L2	Kg	Euro
402.02.20.70	SK 40	AD	ER32 (2 - 20)	70	50	-	-	48	1,21	
403.02.20.70	SK 40	AD/B	ER32 (2 - 20)	70	50	-	-	48	1,20	
402.02.20.100	SK 40	AD	ER32 (2 - 20)	100	50	-	-	48	1,64	
403.02.20.100	SK 40	AD/B	ER32 (2 - 20)	100	50	-	-	48	1,63	
402.02.20.130	SK 40	AD	ER32 (2 - 20)	130	50	-	-	48	2,07	
403.02.20.130	SK 40	AD/B	ER32 (2 - 20)	130	50	-	-	48	2,07	
402.02.20.160	SK 40	AD	ER32 (2 - 20)	160	50	-	-	48	2,50	
403.02.20.160	SK 40	AD/B	ER32 (2 - 20)	160	50	-	-	48	2,50	
403.02.20.200	SK 40	AD/B	ER32 (2 - 20)	200	50	-	-	48	3,08	
402.02.26.80	SK 40	AD	ER40 (3 - 26)	80	63	-	-	55	1,43	
403.02.26.80	SK 40	AD/B	ER40 (3 - 26)	80	63	-	-	55	1,43	
402.02.26.100	SK 40	AD	ER40 (3 - 26)	100	63	-	-	55	1,72	
403.02.26.100	SK 40	AD/B	ER40 (3 - 26)	100	63	-	-	55	1,71	
402.02.26.130	SK 40	AD	ER40 (3 - 26)	130	63	-	-	55	2,15	
403.02.26.130	SK 40	AD/B	ER40 (3 - 26)	130	63	-	-	55	2,15	
402.02.26.160	SK 40	AD	ER40 (3 - 26)	160	63	-	-	55	2,58	
403.02.26.160	SK 40	AD/B	ER40 (3 - 26)	160	63	-	-	55	2,58	
403.02.26.200	SK 40	AD/B	ER40 (3 - 26)	200	63	-	-	55	3,16	

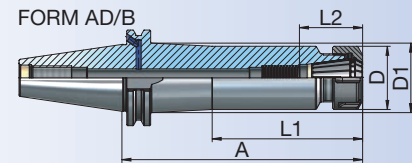
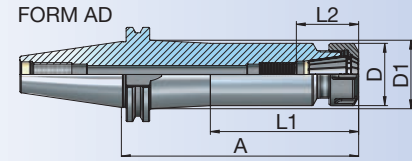

Zubehör / Accessories / Accessoires / Yedekler



Spannzangen System ER
Collets System ER
Pinces de serrage System ER
Pens ER



Spannmutter ER
Clamping nuts ER
Écrou de serrage ER
Pens kapağı ER



Spannschlüssel für ER
Wrench ER
Clé de serrage ER
Anahtar ER



11.01



Spannfutter ER

Collet chucks ER

Mandrin à pinces ER

Pens başlığı ER

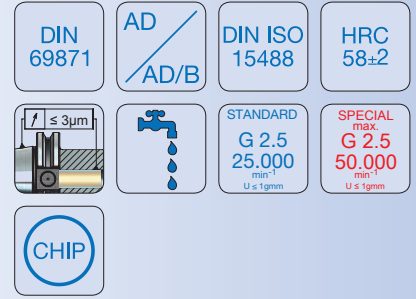

Bestell-Nr. Order Nr. Reference Sipariş Nr.	SK	Form	Spannbereich Capacity Capacité Kapasite								
				A	D	D1	L1	L2	Kg	Euro	
502.02.10.63	SK 50	AD	ER16 (1 - 10)	63	28	-	-	32	2,75		
503.02.10.63	SK 50	AD/B	ER16 (1 - 10)	63	28	-	-	32	2,74		
502.02.10.100	SK 50	AD	ER16 (1 - 10)	100	28	-	-	32	2,90		
503.02.10.100	SK 50	AD/B	ER16 (1 - 10)	100	28	-	-	32	2,88		
502.02.10.130	SK 50	AD	ER16 (1 - 10)	130	28	-	-	32	3,02		
503.02.10.130	SK 50	AD/B	ER16 (1 - 10)	130	28	-	-	32	3,00		
502.02.10.160	SK 50	AD	ER16 (1 - 10)	160	28	32	98	32	3,17		
503.02.10.160	SK 50	AD/B	ER16 (1 - 10)	160	28	32	98	32	3,15		
503.02.10.200	SK 50	AD/B	ER16 (1 - 10)	200	28	33,5	120	32	3,36		
new 503.02.13.70	SK 50	AD/B	ER20 (1 - 13)	70	34	-	-	39,5	2,83		
new 503.02.13.100	SK 50	AD/B	ER20 (1 - 13)	100	34	-	-	39,5	3,02		
new 503.02.13.130	SK 50	AD/B	ER20 (1 - 13)	130	34	-	-	39,5	3,20		
new 503.02.13.160	SK 50	AD/B	ER20 (1 - 13)	160	34	38	99,5	39,5	3,43		
502.02.16.60	SK 50	AD	ER25 (2 - 16)	60	42	-	-	42	2,84		
503.02.16.60	SK 50	AD/B	ER25 (2 - 16)	60	42	-	-	60	2,80		
502.02.16.100	SK 50	AD	ER25 (2 - 16)	100	42	-	-	42	3,23		
503.02.16.100	SK 50	AD/B	ER25 (2 - 16)	100	42	-	-	42	3,22		
502.02.16.130	SK 50	AD	ER25 (2 - 16)	130	42	-	-	42	3,53		
503.02.16.130	SK 50	AD/B	ER25 (2 - 16)	130	42	-	-	42	3,52		
502.02.16.160	SK 50	AD	ER25 (2 - 16)	160	42	46	100	42	3,88		
503.02.16.160	SK 50	AD/B	ER25 (2 - 16)	160	42	46	100	42	3,86		
503.02.16.200	SK 50	AD/B	ER25 (2 - 16)	200	42	47,5	120	42	4,34		

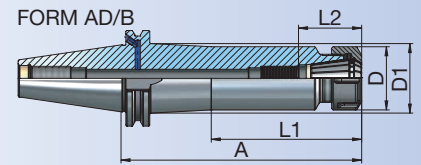
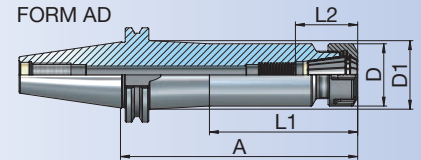

Zubehör / Accessories / Accessoires / Yedekler



Spannzangen System ER
Collets System ER
Pincés de serrage System ER
Pens ER



Spannmutter ER
Clamping nuts ER
Écrou de serrage ER
Pens kapağı ER



Spannschlüssel für ER
Wrench ER
Clé de serrage ER
Anahtar ER



11.01



Spannfutter ER

Collet chucks ER

Mandrin à pinces ER

Pens başlığı ER



Bestell-Nr. Order Nr. Reference Sipariş Nr.	SK	Form	Spannbereich Capacity Capacité Kapasite								
				A	D	D1	L1	L2	Kg	Euro	
502.02.20.70	SK 50	AD	ER32 (2 - 20)	70	50	-	-	48	3,03		
503.02.20.70	SK 50	AD/B	ER32 (2 - 20)	70	50	-	-	69	2,96		
502.02.20.100	SK 50	AD	ER32 (2 - 20)	100	50	-	-	48	3,46		
503.02.20.100	SK 50	AD/B	ER32 (2 - 20)	100	50	-	-	48	3,44		
502.02.20.130	SK 50	AD	ER32 (2 - 20)	130	50	-	-	48	3,90		
503.02.20.130	SK 50	AD/B	ER32 (2 - 20)	130	50	-	-	48	3,88		
502.02.20.160	SK 50	AD	ER32 (2 - 20)	160	50	54	101	48	4,38		
503.02.20.160	SK 50	AD/B	ER32 (2 - 20)	160	50	54	101	48	4,37		
503.02.20.200	SK 50	AD/B	ER32 (2 - 20)	200	50	55,5	120	48	5,04		
502.02.26.80	SK 50	AD	ER40 (3 - 26)	80	63	-	-	55	3,47		
503.02.26.80	SK 50	AD/B	ER40 (3 - 26)	80	63	-	-	55	3,46		
502.02.26.100	SK 50	AD	ER40 (3 - 26)	100	63	-	-	55	3,94		
503.02.26.100	SK 50	AD/B	ER40 (3 - 26)	100	63	-	-	55	3,93		
502.02.26.130	SK 50	AD	ER40 (3 - 26)	130	63	-	-	55	4,65		
503.02.26.130	SK 50	AD/B	ER40 (3 - 26)	130	63	-	-	55	4,63		
502.02.26.160	SK 50	AD	ER40 (3 - 26)	160	63	66,5	103	55	5,41		
503.02.26.160	SK 50	AD/B	ER40 (3 - 26)	160	63	66,5	103	55	5,40		
503.02.26.200	SK 50	AD/B	ER40 (3 - 26)	200	63	69	120	55	6,43		

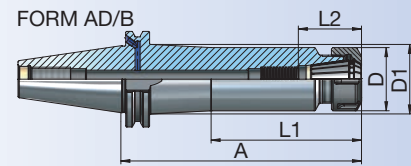
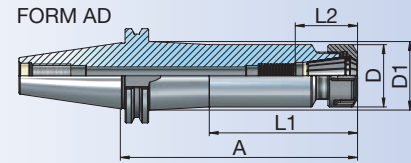

Zubehör / Accessories / Accessoires / Yedekler



Spannzangen System ER
Collets System ER
Pinces de serrage System ER
Pens ER



Spannmütter ER
Clamping nuts ER
Écrou de serrage ER
Pens kapağı ER



Spannschlüssel für ER
Wrench ER
Clé de serrage ER
Anahtar ER



11.01



Spannfutter ER Mini

Collet chucks ER Mini

Mandrin à pincés ER Mini

Pens başlığı ER Mini

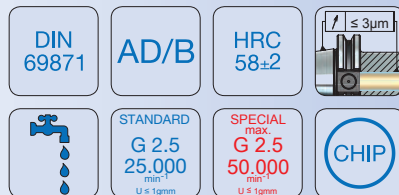

Bestell-Nr. Order Nr. Reference Sipariş Nr.	SK	Form	Spannbereich Capacity Capacité Kapasite	A	D	D1	L1	L2	Kg	Euro
403.02.07.55.M	SK 40	AD/B	ER11 (1 - 7)	55	16	-	-	46,5	0,85	
403.02.07.100.M	SK 40	AD/B	ER11 (1 - 7)	100	16	-	-	41,5	0,91	
403.02.07.130.M	SK 40	AD/B	ER11 (1 - 7)	130	16	-	-	41,5	0,95	
403.02.07.160.M	SK 40	AD/B	ER11 (1 - 7)	160	16	20	94,5	41,5	1,02	
403.02.10.100.M	SK 40	AD/B	ER16 (1 - 10)	100	22	-	-	32	0,98	
403.02.10.130.M	SK 40	AD/B	ER16 (1 - 10)	130	22	-	-	32	1,06	
403.02.10.160.M	SK 40	AD/B	ER16 (1 - 10)	160	22	26	98	32	1,16	
503.02.10.100.M	SK 50	AD/B	ER16 (1 - 10)	100	22	-	-	32	2,79	
503.02.10.130.M	SK 50	AD/B	ER16 (1 - 10)	130	22	-	-	32	2,87	
503.02.10.160.M	SK 50	AD/B	ER16 (1 - 10)	160	22	26	98	32	2,97	

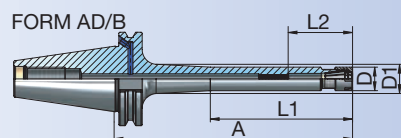

Zubehör / Accessories / Accessoires / Yedekler



Spannzangen System ER
Collets System ER
Pincés de serrage System ER
Pens ER



Spannmutter Mini
Nut Mini
Écrou mini
Mini kapak



Rollenschlüssel für Spannmutter
Roller Bearing Wrenches
Cles à rouleaux
Bilyalı Kapak Sıkma Anahtar



Spannschlüssel
Wrench
Clé de serrage
Anahtar ER



11.01



Spannfuttersatz im Koffer

Collet chuck set in box

Mandrin á pincas pour pincas (set) dans coffre

Pens başlığı seti plastik kutuda

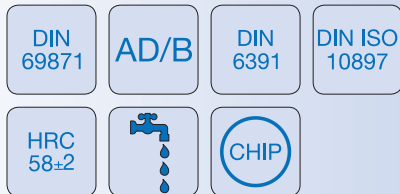

Bestell-Nr. Order Nr. Reference Sipariş Nr.	SK	Form	Abmessung Size Dimension Cinsi	Spannbereich Capacity Capacité Kapasite	Spannzangen Durchmesser Collet Diameter Pincas Diamètre Pens Çapı	Spannzangen Stk. Collet Pcs. Pincas Pens Adedi	Kg	Euro
new 403.61.16.70	SK 40	AD/B	OZ 16	415 E (2 - 16)	4-5-6-7-8-9-10-11-12-14-15-16	12	2,74	
new 403.61.25.70	SK 40	AD/B	OZ 25	462 E (2 - 25)	4-5-6-7-8-9-10-11-12-14-16-18-20-22-24-25	16	5,57	
new 403.61.32.90	SK 40	AD/B	OZ 32	467 E (4 - 32)	6-7-8-9-10-12-14-16-18-20-22-24-25-28-30-32	16	8,94	
new 503.61.25.70	SK 50	AD/B	OZ 25	462 E (2 - 25)	4-5-6-7-8-9-10-11-12-14-16-18-20-22-24-25	16	7,72	
new 503.61.32.80	SK 50	AD/B	OZ 32	467 E (4 - 32)	6-7-8-9-10-12-14-16-18-20-22-24-25-28-30-32	16	10,81	

Lieferumfang : Spannfutter, inkl. Spannzangen mit Schlüssel

Included : Collet chuck with collets and wrench

Inclus : Mandrin avec pincas et clé

Teslim Şekli : Tutucu, pensleri ve anahtarlarıyla birlikte

Zubehör / Accessories / Accessoires / Yedekler

	Spannzangen OZ Collets OZ Pincas de serrage OZ Pens OZ		Spannmutter OZ Clamping nuts OZ Écrou de serrage OZ Pens kapağı OZ		Hakenschlüssel Wrench Clé à ergot E tipi ay anahtar
--	-----------------------------------------------------------------	--	-----------------------------------------------------------------------------	--	--------------------------------------------------------------



Spannfuttersatz im Koffer

Collet chuck set in box

Mandrin á pincas pour pincas (set) dans coffre

Pens başlığı seti plastik kutuda

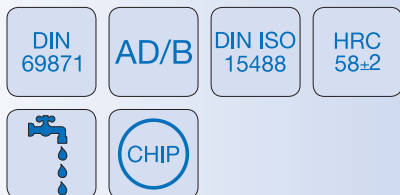

Bestell-Nr. Order Nr. Reference Sipariş Nr.	SK	Form	Spannbereich Capacity Capacité Kapasite	Spannzangen Durchmesser Collet Diameter Pincas Diamètre Pens Çapı	Spannzangen Stk. Collet Pcs. Pincas Pens Adedi	Kg	Euro
new 403.62.16.60	SK 40	AD/B	ER25 (2 - 16)	3-4-5-6-7-8-9-10-11-12-14-16	12	2,53	
new 403.62.20.70	SK 40	AD/B	ER32 (2 - 20)	4-5-6-7-8-9-10-11-12-13-14-15-16-18-20	15	4,45	
new 403.62.26.80	SK 40	AD/B	ER40 (3 - 26)	4-5-6-7-8-9-10-12-14-16-18-20-22-24-25-26	16	6,73	
new 503.62.20.70	SK 50	AD/B	ER32 (2 - 20)	4-5-6-7-8-9-10-11-12-13-14-15-16-18-20	15	7,37	
new 503.62.26.80	SK 50	AD/B	ER40 (3 - 26)	4-5-6-7-8-9-10-12-14-16-18-20-22-24-25-26	16	9,02	

Lieferumfang : Spannfutter, inkl. Spannzangen mit Schlüssel

Included : Collet chuck with collets and wrench

Inclus : Mandrin avec pincas et clé

Teslim Şekli : Tutucu, pensleri ve anahtarlarıyla birlikte

Zubehör / Accessories / Accessoires / Yedekler

	Spannzangen System ER Collets System ER Pincas de serrage System ER Pens ER		Spannmutter ER Clamping nuts ER Écrou de serrage ER Pens kapağı ER		Spannschlüssel für ER Wrench ER Clé de serrage ER Anahtar ER
--	--------------------------------------------------------------------------------------	--	-----------------------------------------------------------------------------	--	-----------------------------------------------------------------------





Ausrichtbares Werkzeugspannfutter, radial und axial einstellbar

Adjustable toolholder, adjustable radial and axial

Mandrin à tige de réglage, réglage radial et axial

Hassas ayarlanabilir pens tutucular, eksenel ve radyal yönde

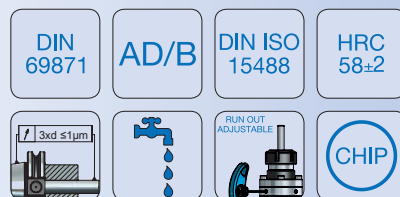

Micro-mec ARF-Plus Ausrichtfutter

Bestell-Nr. Order Nr. Reference Sipariş Nr.	SK	Form	Spannbereich Capacity Capacité Kapasite	D	A	L1	L2	D1	M	M1	Kg	Euro
403.02.20.109.ARF-P	SK 40	AD/B	ER32 (2 - 20)	50	109	47	48	68	M6	M6	2,21	
503.02.20.109.ARF-P	SK 50	AD/B	ER32 (2 - 20)	50	109	47	48	68	M6	M6	4,04	

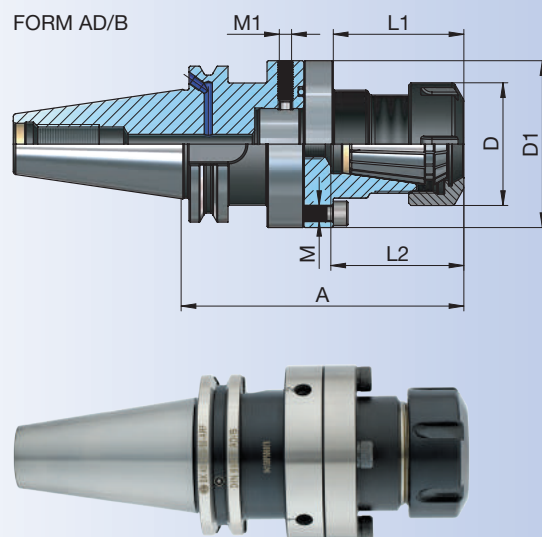

Zubehör / Accessories / Accessoires / Yedekler



Spannzangen System ER
Collets System ER
Pincettes de serrage System ER
Pens ER



Spannmutter ER
Clamping nuts ER
Écrou de serrage ER
Pens kapağı ER



Anzugschraube
Bolt
Trette
Civata



Einstellschraube
Adjusting screw
Vis de réglage
Ayar civatası



Spannschlüssel für ER
Wrench ER
Clé de serrage ER
Anahtar ER



11.04



Präzisionskraftspannfutter

Precision milling chuck

Mandrin de fraisage de précision

Bilyalı pens tutucu

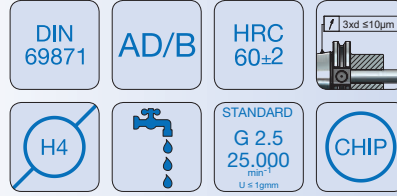

Bestell-Nr. Order Nr. Reference Sipariş Nr.	SK	Form	Spannbereich Capacity Capacité Kapasite	d	A	D	L2	Kg	Euro
new 403.03.20.90.N	SK 40	AD/B	EKS 20 (6-20)	20	90	48	80	1,53	
new 403.03.20.130.N	SK 40	AD/B	EKS 20 (6-20)	20	130	48	80	2,06	
new 403.03.20.160.N	SK 40	AD/B	EKS 20 (6-20)	20	160	48	80	2,45	
new 403.03.20.200.N	SK 40	AD/B	EKS 20 (6-20)	20	200	48	80	2,97	
new 403.03.25.90.N	SK 40	AD/B	EKS 25 (6-25)	25	90	55	80	2,60	
new 403.03.32.100.N	SK 40	AD/B	EKS 32 (6-32)	32	100	68	80	2,28	
new 403.03.32.130.N	SK 40	AD/B	EKS 32 (6-32)	32	130	68	80	2,81	
new 403.03.32.160.N	SK 40	AD/B	EKS 32 (6-32)	32	160	68	80	3,48	
new 403.03.32.200.N	SK 40	AD/B	EKS 32 (6-32)	32	200	68	80	4,41	

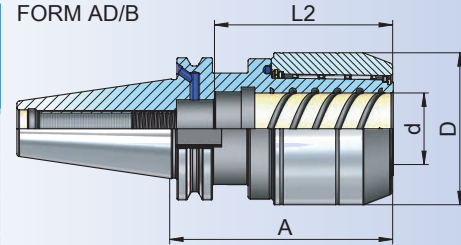

new 503.03.20.70.N	SK 50	AD/B	EKS 20 (6-20)	20	70	48	80	3,19	
new 503.03.20.130.N	SK 50	AD/B	EKS 20 (6-20)	20	130	48	80	3,85	
new 503.03.20.160.N	SK 50	AD/B	EKS 20 (6-20)	20	160	48	80	4,29	
new 503.03.20.200.N	SK 50	AD/B	EKS 20 (6-20)	20	200	48	80	4,85	
new 503.03.32.95.N	SK 50	AD/B	EKS 32 (6-32)	32	95	68	80	3,95	
new 503.03.32.130.N	SK 50	AD/B	EKS 32 (6-32)	32	130	68	80	4,81	
new 503.03.32.160.N	SK 50	AD/B	EKS 32 (6-32)	32	160	68	80	5,50	
new 503.03.32.200.N	SK 50	AD/B	EKS 32 (6-32)	32	200	68	80	6,36	

Zubehör / Accessories / Accessoires / Yedekler



Spannzangen
Collets
Pincés de serrage
Pens



Rollenschlüssel für Spannmutter
Roller Bearing Wrenches
Cles à rouleaux
Bilyalı Kapak Sıkma Anahtarı



Präzisionskraftspannfuttersatz im Koffer

Precision milling chuck set in box

Mandrin de fraisage de précision dans le box

Bilyalı pens tutucu seti plastik kutuda

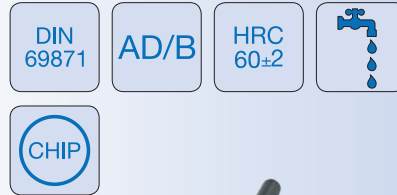

Bestell-Nr. Order Nr. Reference Sipariş Nr.	SK	Form	Spannbereich Capacity Capacité Kapasite	Spannzangen Durchmesser Collet Diameter Pincés Diamètre Pens Çapı	Spannzangen Stk. Collet Pcs. Pincés Pens Adedi	Kg	Euro
new 403.63.20.90.N	SK 40	AD/B	EKS 20 (6-20)	6-8-10-12-16	5	3,26	
new 403.63.32.100.N	SK 40	AD/B	EKS 32 (6-32)	6-8-10-12-16-20-25	7	5,82	
new 503.63.20.70.N	SK 50	AD/B	EKS 20 (6-20)	6-8-10-12-16	5	6,56	
new 503.63.32.95.N	SK 50	AD/B	EKS 32 (6-32)	6-8-10-12-16-20-25	7	8,53	



Zubehör / Accessories / Accessoires / Yedekler



Spannzangen
Collets
Pincés de serrage
Pens



Rollenschlüssel für Spannmutter
Roller Bearing Wrenches
Cles à rouleaux
Bilyalı Kapak Sıkma Anahtarı



Lieferumfang : Spannfutter, inkl. Spannzangen mit Schlüssel
Included : Collet chuck with collets and wrench
Inclus : Mandrin avec pincés et clé
Teslim Şekli : Tutucu, pensleri ve anahtarlarıyla birlikte



Fräseraufnahmen

End mill holder

Porte-fraises

Veldon tutucu

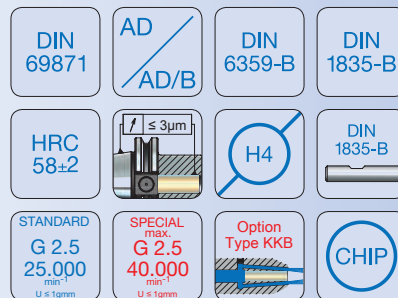

Bestell-Nr. Order Nr. Reference Sipariş Nr.	SK	Form	d	A	D	D1	L1	L2	Kg	Euro
302.04.06.50	SK 30	AD	6	50	25	-	-	36	0,46	
302.04.08.50	SK 30	AD	8	50	28	-	-	40	0,49	
302.04.10.50	SK 30	AD	10	50	35	-	-	44	0,55	
302.04.12.50	SK 30	AD	12	50	42	-	-	51	0,62	
302.04.14.63	SK 30	AD	14	63	44	-	-	51	0,78	
302.04.16.63	SK 30	AD	16	63	48	-	-	54	0,82	
302.04.18.63	SK 30	AD	18	63	50	-	-	54	0,83	
302.04.20.70	SK 30	AD	20	70	52	-	-	56	0,91	
402.04.06.50	SK 40	AD	6	50	25	-	-	36	0,91	
403.04.06.50	SK 40	AD/B	6	50	25	-	-	36	0,90	
402.04.06.100	SK 40	AD	6	100	25	-	-	36	1,08	
403.04.06.100	SK 40	AD/B	6	100	25	-	-	36	1,07	
402.04.06.130	SK 40	AD	6	130	25	-	-	36	1,18	
403.04.06.130	SK 40	AD/B	6	130	25	-	-	36	1,18	
402.04.06.160	SK 40	AD	6	160	25	30,5	88	36	1,33	
403.04.06.160	SK 40	AD/B	6	160	25	30,5	88	36	1,33	
403.04.06.200	SK 40	AD/B	6	200	25	31	120	36	1,48	
402.04.08.50	SK 40	AD	8	50	28	-	-	40	0,93	
403.04.08.50	SK 40	AD/B	8	50	28	-	-	40	0,93	
402.04.08.100	SK 40	AD	8	100	28	-	-	40	1,15	
403.04.08.100	SK 40	AD/B	8	100	28	-	-	40	1,15	
402.04.08.130	SK 40	AD	8	130	28	-	-	40	1,29	
403.04.08.130	SK 40	AD/B	8	130	28	-	-	40	1,28	
402.04.08.160	SK 40	AD	8	160	28	33,5	88	40	1,47	
403.04.08.160	SK 40	AD/B	8	160	28	33,5	88	40	1,47	
403.04.08.200	SK 40	AD/B	8	200	28	34	120	40	1,66	

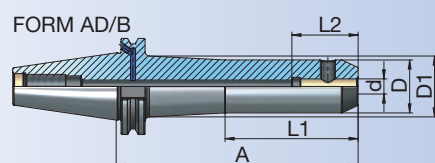
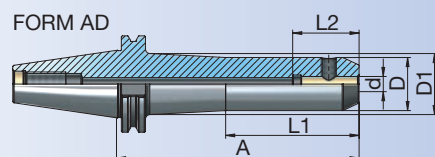

Zubehör / Accessories / Accessoires / Yedekler



Spannschrauben
Clamping screw
Vis de serrage
Sıkma civatası





Fräseraufnahmen

End mill holder

Porte-fraises

Veldon tutucu

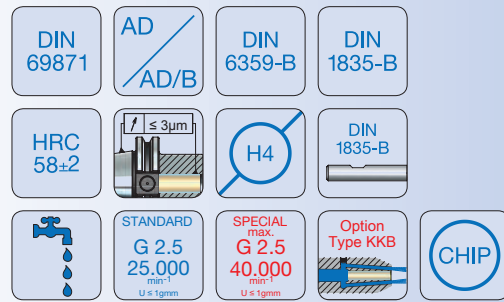

Bestell-Nr. Order Nr. Reference Sipariş Nr.	SK	Form	d	A	D	D1	L1	L2	Kg	Euro
402.04.10.50	SK 40	AD	10	50	35	-	-	44	0,98	
403.04.10.50	SK 40	AD/B	10	50	35	-	-	44	0,98	
402.04.10.100	SK 40	AD	10	100	35	-	-	44	1,31	
403.04.10.100	SK 40	AD/B	10	100	35	-	-	44	1,31	
402.04.10.130	SK 40	AD	10	130	35	-	-	44	1,52	
403.04.10.130	SK 40	AD/B	10	130	35	-	-	44	1,51	
402.04.10.160	SK 40	AD	10	160	35	40,5	88	44	1,78	
403.04.10.160	SK 40	AD/B	10	160	35	40,5	88	44	1,78	
403.04.10.200	SK 40	AD/B	10	200	35	41	120	44	2,06	
402.04.12.50	SK 40	AD	12	50	42	-	-	51	1,05	
403.04.12.50	SK 40	AD/B	12	50	42	-	-	51	1,05	
402.04.12.100	SK 40	AD	12	100	42	-	-	51	1,55	
403.04.12.100	SK 40	AD/B	12	100	42	-	-	51	1,55	
402.04.12.130	SK 40	AD	12	130	42	-	-	51	1,85	
403.04.12.130	SK 40	AD/B	12	130	42	-	-	51	1,85	
402.04.12.160	SK 40	AD	12	160	42	47,5	88	51	2,22	
403.04.12.160	SK 40	AD/B	12	160	42	47,5	88	51	2,22	
403.04.12.200	SK 40	AD/B	12	200	42	48,5	120	51	2,64	
402.04.14.50	SK 40	AD	14	50	44	-	-	51	1,07	
403.04.14.50	SK 40	AD/B	14	50	44	-	-	51	1,06	
402.04.14.100	SK 40	AD	14	100	44	-	-	51	1,62	
403.04.14.100	SK 40	AD/B	14	100	44	-	-	51	1,61	
402.04.14.130	SK 40	AD	14	130	44	-	-	51	1,95	
403.04.14.130	SK 40	AD/B	14	130	44	-	-	51	1,94	
402.04.14.160	SK 40	AD	14	160	44	-	-	51	2,28	
403.04.14.160	SK 40	AD/B	14	160	44	-	-	51	2,27	
403.04.14.200	SK 40	AD/B	14	200	44	-	-	51	2,71	

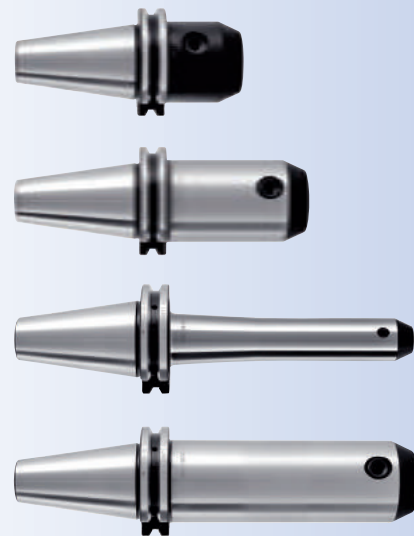
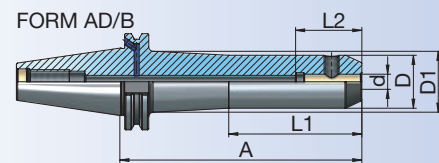
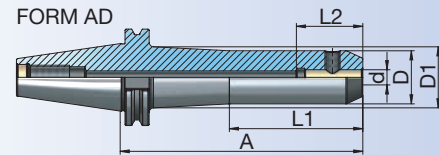

Zubehör / Accessories / Accessoires / Yedekler





Fräseraufnahmen

End mill holder

Porte-fraises

Veldon tutucu

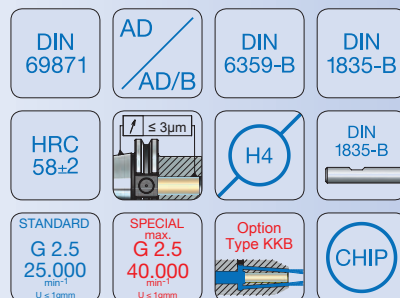

Bestell-Nr. Order Nr. Reference Sipariş Nr.	SK	Form	d	A	D	D1	L1	L2	Kg	Euro
402.04.16.35	SK 40	AD	16	35	45	-	-	54	0,88	
402.04.16.63	SK 40	AD	16	63	48	-	-	54	1,28	
403.04.16.63	SK 40	AD/B	16	63	48	-	-	54	1,28	
402.04.16.100	SK 40	AD	16	100	48	-	-	54	1,77	
403.04.16.100	SK 40	AD/B	16	100	48	-	-	54	1,77	
402.04.16.130	SK 40	AD	16	130	48	-	-	54	2,17	
403.04.16.130	SK 40	AD/B	16	130	48	-	-	54	2,16	
402.04.16.160	SK 40	AD	16	160	48	-	-	54	2,56	
403.04.16.160	SK 40	AD/B	16	160	48	-	-	54	2,56	
403.04.16.200	SK 40	AD/B	16	200	48	-	-	54	3,09	
402.04.18.63	SK 40	AD	18	63	50	-	-	54	1,31	
403.04.18.63	SK 40	AD/B	18	63	50	-	-	54	1,29	
402.04.18.100	SK 40	AD	18	100	50	-	-	54	1,84	
403.04.18.100	SK 40	AD/B	18	100	50	-	-	54	1,83	
402.04.18.130	SK 40	AD	18	130	50	-	-	54	2,27	
403.04.18.130	SK 40	AD/B	18	130	50	-	-	54	2,27	
402.04.18.160	SK 40	AD	18	160	50	-	-	54	2,71	
403.04.18.160	SK 40	AD/B	18	160	50	-	-	54	2,70	
403.04.18.200	SK 40	AD/B	18	200	50	-	-	54	3,28	
402.04.20.35	SK 40	AD	20	35	50	-	-	56	0,85	
402.04.20.63	SK 40	AD	20	63	52	-	-	56	1,31	
403.04.20.63	SK 40	AD/B	20	63	52	-	-	56	1,30	
402.04.20.100	SK 40	AD	20	100	52	-	-	56	1,88	
403.04.20.100	SK 40	AD/B	20	100	52	-	-	56	1,88	
402.04.20.130	SK 40	AD	20	130	52	-	-	56	2,35	
403.04.20.130	SK 40	AD/B	20	130	52	-	-	56	2,35	
402.04.20.160	SK 40	AD	20	160	52	-	-	56	2,82	
403.04.20.160	SK 40	AD/B	20	160	52	-	-	56	2,82	
403.04.20.200	SK 40	AD/B	20	200	52	-	-	56	3,45	

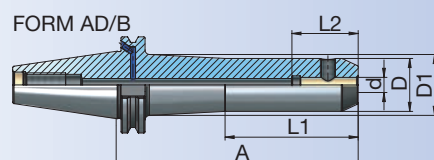
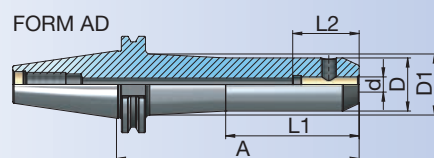

Zubehör / Accessories / Accessoires / Yedekler



Spannschrauben
Clamping screw
Vis de serrage
Sıkma civatası





Fräseraufnahmen

End mill holder

Porte-fraises

Veldon tutucu

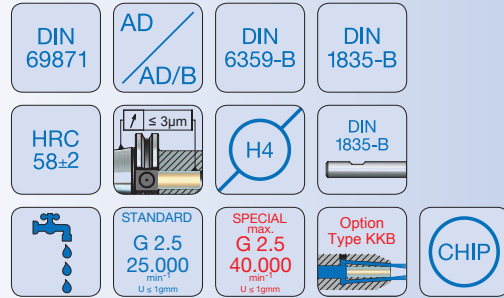

Bestell-Nr. Order Nr. Reference Sipariş Nr.	SK	Form	d	A	D	D1	L1	L2	Kg	Euro
402.04.25.35	SK 40	AD	25	35	50	-	-	64	0,77	
402.04.25.100	SK 40	AD	25	100	63	-	-	64	2,25	
403.04.25.100	SK 40	AD/B	25	100	63	-	-	64	2,25	
402.04.25.130	SK 40	AD	25	130	63	-	-	64	2,95	
403.04.25.130	SK 40	AD/B	25	130	63	-	-	64	2,95	
402.04.25.160	SK 40	AD	25	160	63	-	-	64	3,66	
403.04.25.160	SK 40	AD/B	25	160	63	-	-	64	3,65	
403.04.25.200	SK 40	AD/B	25	200	63	-	-	64	4,59	
402.04.32.65	SK 40	AD	32	65	50	-	-	68	1,09	
402.04.32.100	SK 40	AD	32	100	72	-	-	68	2,55	
403.04.32.100	SK 40	AD/B	32	100	72	-	-	68	2,54	
402.04.32.130	SK 40	AD	32	130	72	-	-	68	3,47	
403.04.32.130	SK 40	AD/B	32	130	72	-	-	68	3,47	
402.04.32.160	SK 40	AD	32	160	72	-	-	68	4,40	
403.04.32.160	SK 40	AD/B	32	160	72	-	-	68	4,39	
402.04.40.120	SK 40	AD	40	120	80	-	-	78	3,42	
403.04.40.120	SK 40	AD/B	40	120	80	-	-	78	3,42	

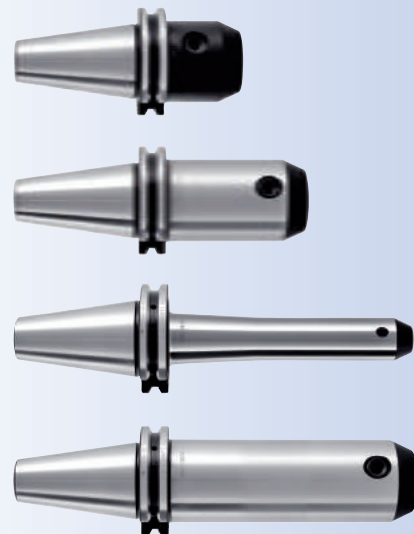
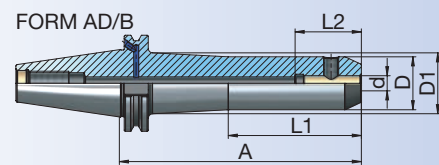
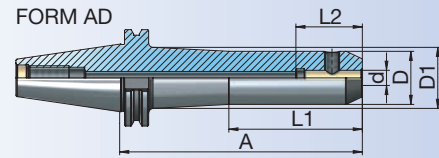

Zubehör / Accessories / Accessoires / Yedekler



Spannschrauben
Clamping screw
Wis de serrage
Sikma civatası





Fräseraufnahmen

End mill holder

Porte-fraises

Veldon tutucu

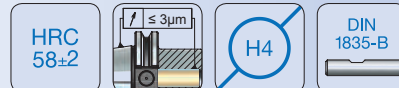

Bestell-Nr. Order Nr. Reference Sipariş Nr.	SK	Form	d	A	D	D1	L1	L2	Kg	Euro
502.04.06.63	SK 50	AD	6	63	25	-	-	36	2,77	
503.04.06.63	SK 50	AD/B	6	63	25	-	-	36	2,75	
502.04.06.100	SK 50	AD	6	100	25	-	-	36	2,89	
503.04.06.100	SK 50	AD/B	6	100	25	-	-	36	2,88	
502.04.06.130	SK 50	AD	6	130	25	-	-	36	3,00	
503.04.06.130	SK 50	AD/B	6	130	25	-	-	36	2,98	
502.04.06.160	SK 50	AD	6	160	25	30,5	88	36	3,15	
503.04.06.160	SK 50	AD/B	6	160	25	30,5	88	36	3,13	
503.04.06.200	SK 50	AD/B	6	200	25	30,5	120	36	3,30	
502.04.08.63	SK 50	AD	8	63	28	-	-	40	2,81	
503.04.08.63	SK 50	AD/B	8	63	28	-	-	40	2,79	
502.04.08.100	SK 50	AD	8	100	28	-	-	40	2,97	
503.04.08.100	SK 50	AD/B	8	100	28	-	-	40	2,96	
502.04.08.130	SK 50	AD	8	130	28	-	-	40	3,10	
503.04.08.130	SK 50	AD/B	8	130	28	-	-	40	3,09	
502.04.08.160	SK 50	AD	8	160	28	33,5	88	40	3,29	
503.04.08.160	SK 50	AD/B	8	160	28	33,5	88	40	3,27	
503.04.08.200	SK 50	AD/B	8	200	28	33,5	120	40	3,48	
502.04.10.63	SK 50	AD	10	63	35	-	-	44	2,88	
503.04.10.63	SK 50	AD/B	10	63	35	-	-	44	2,87	
502.04.10.100	SK 50	AD	10	100	35	-	-	44	3,13	
503.04.10.100	SK 50	AD/B	10	100	35	-	-	44	3,11	
502.04.10.130	SK 50	AD	10	130	35	-	-	44	3,33	
503.04.10.130	SK 50	AD/B	10	130	35	-	-	44	3,31	
502.04.10.160	SK 50	AD	10	160	35	40,5	88	44	3,59	
503.04.10.160	SK 50	AD/B	10	160	35	40,5	88	44	3,58	
503.04.10.200	SK 50	AD/B	10	200	35	40,5	120	44	3,88	

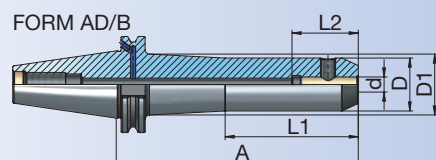
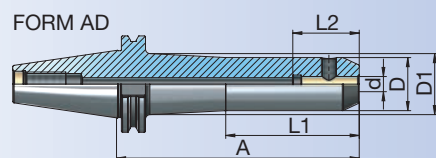

Zubehör / Accessories / Accessoires / Yedekler



Spannschrauben
Clamping screw
Vis de serrage
Sıkma civatası





Fräseraufnahmen

End mill holder

Porte-fraises

Veldon tutucu

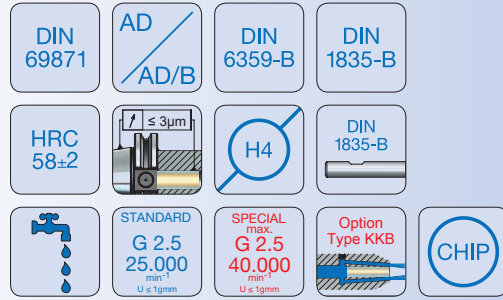

Bestell-Nr. Order Nr. Reference Sipariş Nr.	SK	Form	d	A	D	D1	L1	L2	Kg	Euro
502.04.12.63	SK 50	AD	12	63	42	-	-	51	3,00	
503.04.12.63	SK 50	AD/B	12	63	42	-	-	51	2,99	
502.04.12.100	SK 50	AD	12	100	42	-	-	51	3,37	
503.04.12.100	SK 50	AD/B	12	100	42	-	-	51	3,35	
502.04.12.130	SK 50	AD	12	130	42	-	-	51	3,67	
503.04.12.130	SK 50	AD/B	12	130	42	-	-	51	3,65	
502.04.12.160	SK 50	AD	12	160	42	47,5	88	51	4,05	
503.04.12.160	SK 50	AD/B	12	160	42	47,5	88	51	4,03	
503.04.12.200	SK 50	AD/B	12	200	42	47,5	120	51	4,47	
502.04.14.63	SK 50	AD	14	63	44	-	-	51	3,03	
503.04.14.63	SK 50	AD/B	14	63	44	-	-	51	3,01	
502.04.14.100	SK 50	AD	14	100	44	-	-	51	3,44	
503.04.14.100	SK 50	AD/B	14	100	44	-	-	51	3,42	
502.04.14.130	SK 50	AD	14	130	44	-	-	51	3,77	
503.04.14.130	SK 50	AD/B	14	130	44	-	-	51	3,75	
502.04.14.160	SK 50	AD	14	160	44	49,5	88	51	4,18	
503.04.14.160	SK 50	AD/B	14	160	44	49,5	88	51	4,17	
503.04.14.200	SK 50	AD/B	14	200	44	49,5	120	51	4,65	
502.04.16.63	SK 50	AD	16	63	48	-	-	54	3,10	
503.04.16.63	SK 50	AD/B	16	63	48	-	-	54	3,08	
502.04.16.100	SK 50	AD	16	100	48	-	-	54	3,59	
503.04.16.100	SK 50	AD/B	16	100	48	-	-	54	3,57	
502.04.16.130	SK 50	AD	16	130	48	-	-	54	3,99	
503.04.16.130	SK 50	AD/B	16	130	48	-	-	54	3,97	
502.04.16.160	SK 50	AD	16	160	48	53,5	88	54	4,48	
503.04.16.160	SK 50	AD/B	16	160	48	53,5	88	54	4,46	
503.04.16.200	SK 50	AD/B	16	200	48	53,5	120	54	5,04	

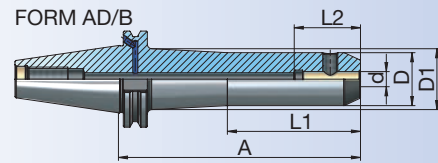
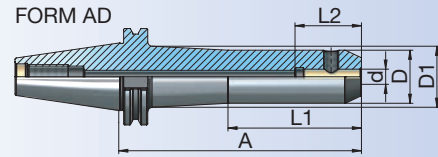

Zubehör / Accessories / Accessoires / Yedekler



Spannschrauben
Clamping screw
Vis de serrage
Sıkma civatası



11.05



Fräseraufnahmen

End mill holder

Porte-fraises

Veldon tutucu

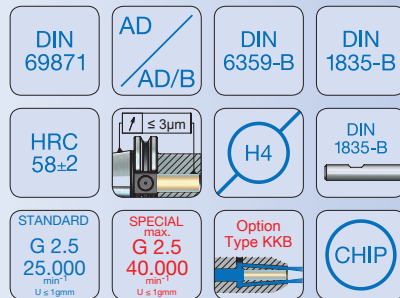

Bestell-Nr. Order Nr. Reference Sipariş Nr.	SK	Form	d	A	D	D1	L1	L2	Kg	Euro
502.04.18.63	SK 50	AD	18	63	50	-	-	54	3,13	
503.04.18.63	SK 50	AD/B	18	63	50	-	-	54	3,11	
502.04.18.100	SK 50	AD	18	100	50	-	-	54	3,66	
503.04.18.100	SK 50	AD/B	18	100	50	-	-	54	3,64	
502.04.18.130	SK 50	AD	18	130	50	-	-	54	4,10	
503.04.18.130	SK 50	AD/B	18	130	50	-	-	54	4,08	
502.04.18.160	SK 50	AD	18	160	50	55,5	88	54	4,62	
503.04.18.160	SK 50	AD/B	18	160	50	55,5	88	54	4,61	
503.04.18.200	SK 50	AD/B	18	200	50	55,5	120	54	5,24	
502.04.20.63	SK 50	AD	20	63	52	-	-	56	3,14	
503.04.20.63	SK 50	AD/B	20	63	52	-	-	56	3,13	
502.04.20.100	SK 50	AD	20	100	52	-	-	56	3,72	
503.04.20.100	SK 50	AD/B	20	100	52	-	-	56	3,71	
502.04.20.130	SK 50	AD	20	130	52	-	-	56	4,20	
503.04.20.130	SK 50	AD/B	20	130	52	-	-	56	4,18	
502.04.20.160	SK 50	AD	20	160	52	57,5	88	56	4,77	
503.04.20.160	SK 50	AD/B	20	160	52	57,5	88	56	4,75	
503.04.20.200	SK 50	AD/B	20	200	52	58	120	56	5,41	
502.04.25.80	SK 50	AD	25	80	63	-	-	64	3,74	
503.04.25.80	SK 50	AD/B	25	80	63	-	-	64	3,73	
502.04.25.100	SK 50	AD	25	100	63	-	-	64	4,21	
503.04.25.100	SK 50	AD/B	25	100	63	-	-	64	4,2	
502.04.25.120	SK 50	AD	25	120	63	-	-	64	4,68	
503.04.25.120	SK 50	AD/B	25	120	63	-	-	64	4,67	
502.04.25.130	SK 50	AD	25	130	63	-	-	64	4,92	
503.04.25.130	SK 50	AD/B	25	130	63	-	-	64	4,91	
502.04.25.160	SK 50	AD	25	160	63	68,5	88	64	5,73	
503.04.25.160	SK 50	AD/B	25	160	63	68,5	88	64	5,72	

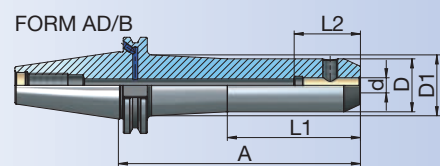
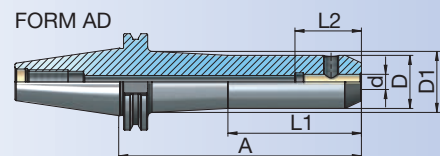

Zubehör / Accessories / Accessoires / Yedekler



Spannschrauben
Clamping screw
Vis de serrage
Sıkma civatası





Fräseraufnahmen

End mill holder

Porte-fraises

Veldon tutucu

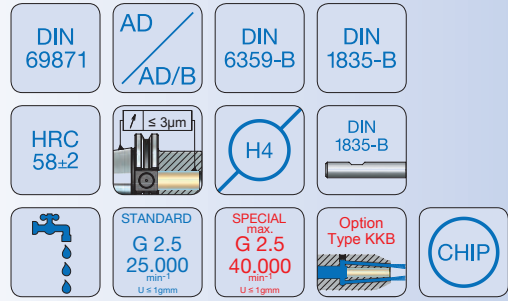

Bestell-Nr. Order Nr. Reference Sipariş Nr.	SK	Form	d	A	D	D1	L1	L2	Kg	Euro
502.04.32.100	SK 50	AD	32	100	72	-	-	68	4,63	
503.04.32.100	SK 50	AD/B	32	100	72	-	-	68	4,61	
502.04.32.130	SK 50	AD	32	130	72	-	-	68	5,55	
503.04.32.130	SK 50	AD/B	32	130	72	-	-	68	5,54	
502.04.32.160	SK 50	AD	32	160	72	-	-	68	6,48	
503.04.32.160	SK 50	AD/B	32	160	72	-	-	68	6,46	
502.04.40.100	SK 50	AD	40	100	80	-	-	78	4,84	
503.04.40.100	SK 50	AD/B	40	100	80	-	-	78	4,82	
502.04.40.130	SK 50	AD	40	130	80	-	-	78	5,99	
503.04.40.130	SK 50	AD/B	40	130	80	-	-	78	5,97	
502.04.40.160	SK 50	AD	40	160	80	-	-	78	7,14	
503.04.40.160	SK 50	AD/B	40	160	80	-	-	78	7,12	

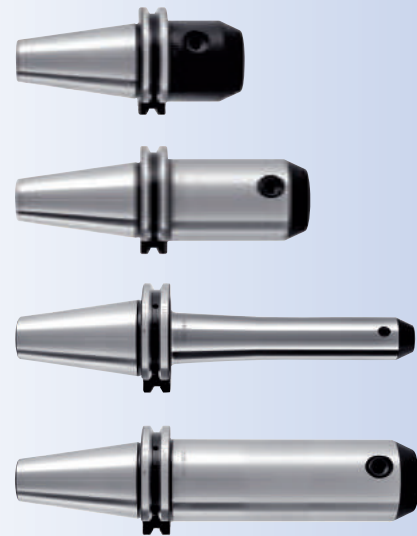
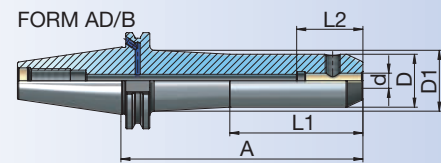
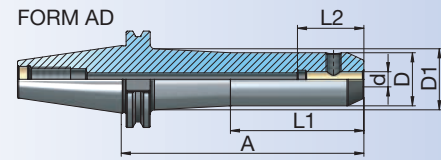

Zubehör / Accessories / Accessoires / Yedekler



Spannschrauben
Clamping screw
Vis de serrage
Sıkma civatası





Fräseraufnahmen mit Kühlkanal

End mill holder with coolant channel

Porte-fraises avec canal d'arrosage

Veldon tutucu içten soğutma kanallı

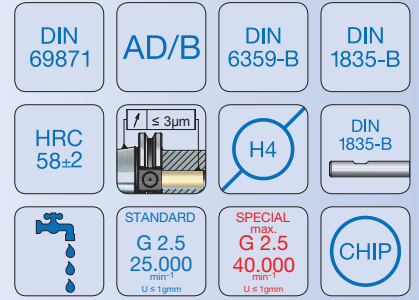

Bestell-Nr. Order Nr. Reference Sipariş Nr.	SK	Form	d	A	D	L2	Kg	Euro
403.04.06.50.K	SK 40	AD/B	6	50	25	36	0,90	
403.04.06.100.K	SK 40	AD/B	6	100	25	36	1,07	
403.04.08.50.K	SK 40	AD/B	8	50	28	40	0,93	
403.04.08.100.K	SK 40	AD/B	8	100	28	40	1,15	
403.04.10.50.K	SK 40	AD/B	10	50	35	44	0,97	
403.04.10.100.K	SK 40	AD/B	10	100	35	44	1,30	
403.04.12.50.K	SK 40	AD/B	12	50	42	51	1,05	
403.04.12.100.K	SK 40	AD/B	12	100	42	51	1,54	
403.04.14.50.K	SK 40	AD/B	14	50	44	51	1,06	
403.04.14.100.K	SK 40	AD/B	14	100	44	51	1,61	
403.04.16.63.K	SK 40	AD/B	16	63	48	54	1,27	
403.04.16.100.K	SK 40	AD/B	16	100	48	54	1,75	
403.04.18.63.K	SK 40	AD/B	18	63	50	54	1,29	
403.04.18.100.K	SK 40	AD/B	18	100	50	54	1,82	
403.04.20.63.K	SK 40	AD/B	20	63	52	56	1,29	
403.04.20.100.K	SK 40	AD/B	20	100	52	56	1,87	
403.04.25.100.K	SK 40	AD/B	25	100	63	64	2,22	
403.04.32.100.K	SK 40	AD/B	32	100	72	68	2,52	
403.04.40.120.K	SK 40	AD/B	40	120	80	78	3,38	

503.04.06.63.K	SK 50	AD/B	6	63	25	36	2,75	
503.04.08.63.K	SK 50	AD/B	8	63	28	40	2,79	
503.04.10.63.K	SK 50	AD/B	10	63	35	44	2,86	
503.04.12.63.K	SK 50	AD/B	12	63	42	51	2,98	
503.04.14.63.K	SK 50	AD/B	14	63	44	51	3,01	
503.04.16.63.K	SK 50	AD/B	16	63	48	54	3,07	
503.04.18.63.K	SK 50	AD/B	18	63	50	54	3,10	
503.04.20.63.K	SK 50	AD/B	20	63	52	56	3,11	
503.04.25.80.K	SK 50	AD/B	25	80	63	64	3,70	
503.04.32.100.K	SK 50	AD/B	32	100	72	68	4,59	
503.04.40.100.K	SK 50	AD/B	40	100	80	78	4,79	

FORM AD/B

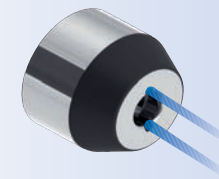
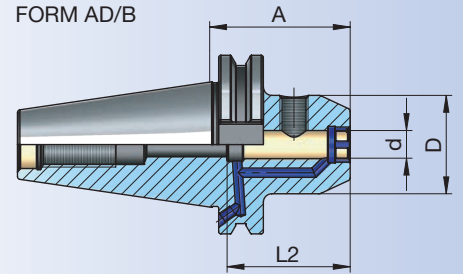

d
6 - 18
(2 Holes)
(2 Delik)

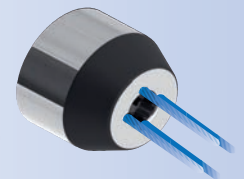

d
20 - 40
(4 Holes)
(4 Delik)

Zubehör / Accessories / Accessoires / Yedekler



Spannschrauben
Clamping screw
Vis de serrage
Sıkma civatası



11.05



Fräseraufnahmen 2° Whistle-Notch

End mill holder 2°

Porte-fraises 2°

Veldon tutucu 2°

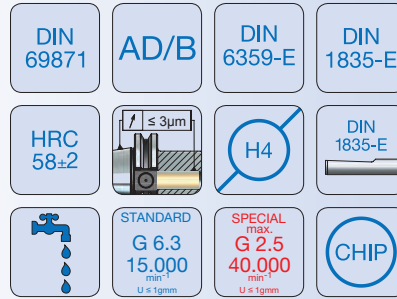

Bestell-Nr. Order Nr. Reference Sipariş Nr.	SK	Form	d	A	D	L2	Kg	Euro
403.05.06.50	SK 40	AD/B	6	50	25	36	0,91	
403.05.08.50	SK 40	AD/B	8	50	28	40	0,94	
403.05.10.50	SK 40	AD/B	10	50	35	44	0,99	
403.05.12.50	SK 40	AD/B	12	50	42	51	1,07	
403.05.14.50	SK 40	AD/B	14	50	44	51	1,08	
403.05.16.63	SK 40	AD/B	16	63	48	54	1,29	
403.05.18.63	SK 40	AD/B	18	63	50	54	1,32	
403.05.20.63	SK 40	AD/B	20	63	52	56	1,32	
403.05.25.100	SK 40	AD/B	25	100	63	64	2,25	
403.05.32.100	SK 40	AD/B	32	100	72	68	2,55	
403.05.40.120	SK 40	AD/B	40	120	80	78	3,43	
503.05.06.63	SK 50	AD/B	6	63	25	36	2,76	
503.05.08.63	SK 50	AD/B	8	63	28	40	2,80	
503.05.10.63	SK 50	AD/B	10	63	35	44	2,88	
503.05.12.63	SK 50	AD/B	12	63	42	51	3,00	
503.05.14.63	SK 50	AD/B	14	63	44	51	3,03	
503.05.16.63	SK 50	AD/B	16	63	48	59	3,09	
503.05.18.63	SK 50	AD/B	18	63	50	59	3,12	
503.05.20.63	SK 50	AD/B	20	63	52	58	3,14	
503.05.25.80	SK 50	AD/B	25	80	63	74	3,70	
503.05.32.100	SK 50	AD/B	32	100	72	68	4,62	
503.05.40.100	SK 50	AD/B	40	100	80	78	4,84	

FORM AD/B

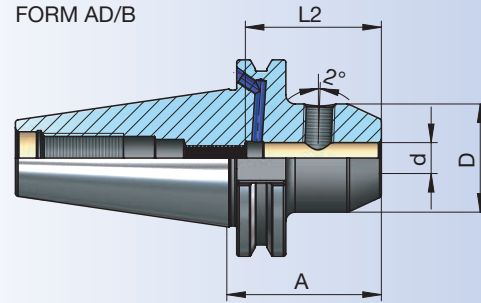

Zubehör / Accessories / Accessoires / Yedekler



Spannschrauben
Clamping screw
Vis de serrage
Sıkma civatası



Einstellschraube
Adjusting screw
Vis de réglage
Dayama civatası



Hochgenauigkeits-Spannzangenfutter

High precision pull type collet chuck

Mandrin de serrage de précision

Hassas çekirtmeli pens başlığı

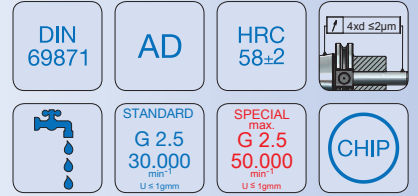

Bestell-Nr. Order Nr. Reference Sipariş Nr.	SK	Form	Spannbereich Capacity Capacité Kapasite	A	D	D1	L	L1	Kg	Euro
new 402.06.06.115	SK 40	AD	EPC (3-6)	115	14	-	50	-	1,54	
new 402.06.06.140	SK 40	AD	EPC (3-6)	140	14	16,7	75	40	1,58	
new 402.06.06.165	SK 40	AD	EPC (3-6)	165	14	19,3	100	40	1,63	
new 402.06.06.215	SK 40	AD	EPC (3-6)	215	14	24,8	150	40	1,78	
new 402.06.08.115	SK 40	AD	EPC (3-8)	115	20	-	50	-	1,59	
new 402.06.08.140	SK 40	AD	EPC (3-8)	140	20	22,9	75	40	1,66	
new 402.06.08.165	SK 40	AD	EPC (3-8)	165	20	25,7	100	40	1,75	
new 402.06.08.215	SK 40	AD	EPC (3-8)	215	20	31,2	150	40	2,00	
new 402.06.12.140	SK 40	AD	EPC (3-12)	140	26	28,1	75	50	1,72	
new 402.06.12.165	SK 40	AD	EPC (3-12)	165	26	30,9	100	50	1,85	
new 402.06.12.215	SK 40	AD	EPC (3-12)	215	26	34,7	150	50	2,15	
new 402.06.16.140	SK 40	AD	EPC (3-16)	140	30	-	75	-	1,74	
new 402.06.16.165	SK 40	AD	EPC (3-16)	165	30	34,1	100	60	1,91	
new 402.06.16.215	SK 40	AD	EPC (3-16)	215	30	34,7	150	60	2,23	

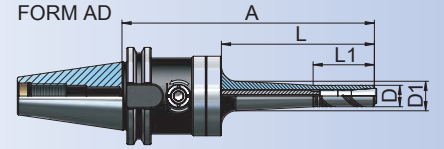

Spannzangen Größe Collet size Diamètre de pince Pens ölçüsü (mm)	Max. Anzugskraft Max. Clamping torque Couple max. Max. Sıkma torku (Nm)	Max. Haltekraft Max. Holding torque Force de serrage Max. Tutma torku (Nm)
EPC 6 (Ø3-Ø6)	4	16
EPC 8 (Ø3-Ø8)	15	50
EPC 12 (Ø3-Ø12)	20	160
EPC 16 (Ø3-Ø16)	25	260

Zubehör / Accessories / Accessoires / Yedekler

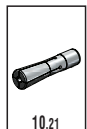

Spannzangen
Collets
Pincés de serrage
Pens



Spannschlüssel
Wrench
Clé de serrage
Sıkma anahtarı





Hochgenauigkeits-Spannzangenfutter

High precision pull type collet chuck

Mandrin de serrage de précision

Hassas çekirmeli pens başlığı



Bestell-Nr. Order Nr. Reference Sipariş Nr.	SK	Form	Spannbereich Capacity Capacité Kapasite	A	D	D1	L	L1	Kg	Euro
new 502.06.06.115	SK 50	AD	EPC (3-6)	115	14	-	50	-	3,35	
new 502.06.06.140	SK 50	AD	EPC (3-6)	140	14	16,7	75	40	3,40	
new 502.06.06.165	SK 50	AD	EPC (3-6)	165	14	19,3	100	40	3,45	
new 502.06.06.215	SK 50	AD	EPC (3-6)	215	14	24,8	150	40	3,59	
new 502.06.08.115	SK 50	AD	EPC (3-8)	115	20	-	50	-	3,41	
new 502.06.08.140	SK 50	AD	EPC (3-8)	140	20	22,9	75	40	3,48	
new 502.06.08.165	SK 50	AD	EPC (3-8)	165	20	25,7	100	40	3,57	
new 502.06.08.215	SK 50	AD	EPC (3-8)	215	20	31,2	150	40	3,82	
new 502.06.12.140	SK 50	AD	EPC (3-12)	140	26	28,1	75	50	3,54	
new 502.06.12.165	SK 50	AD	EPC (3-12)	165	26	30,9	100	50	3,66	
new 502.06.12.215	SK 50	AD	EPC (3-12)	215	26	34,7	150	50	3,97	
new 502.06.16.140	SK 50	AD	EPC (3-16)	140	30	-	75	-	3,56	
new 502.06.16.165	SK 50	AD	EPC (3-16)	165	30	34,1	100	60	3,73	
new 502.06.16.215	SK 50	AD	EPC (3-16)	215	30	34,7	150	60	4,05	

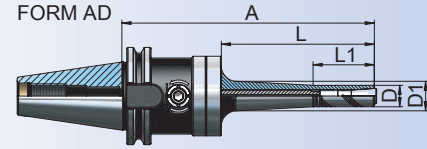

Spannzangen Größe Collet size Diamètre de pince Pens ölçüsü (mm)	Max. Anzugskraft Max. Clamping torque Couple max. Max. Sıkma torku (Nm)	Max. Haltekraft Max. Holding torque Force de serrage Max. Tutma torku (Nm)
EPC 6 (Ø3-Ø6)	4	16
EPC 8 (Ø3-Ø8)	15	50
EPC 12 (Ø3-Ø12)	20	160
EPC 16 (Ø3-Ø16)	25	260

Zubehör / Accessories / Accessoires / Yedekler

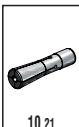

Spannzangen
Collets
Pinces de serrage
Pens

10.21



Spannschlüssel
Wrench
Clé de serrage
Sıkma anahtarı

10.49



11.12



Hochgenauigkeits-Spannzangenfutter im Koffer

High precision pull type collet chuck set in box

Mandrin de serrage de précision (set) dans coffre

Hassas çekilmeli pens başlığı seti plastik kutuda

DIN
69871

AD

HRC
58±2



Bestell-Nr. Order Nr. Reference Sipariş Nr.	SK	Form	Spannbereich Capacity Capacité Kapasite	Spannzangen Durchmesser Collet Diameter Pinces Diamètre Pens Çapı	Spannzangen Stk. Collet Pcs. Pinces Pens Adedi	Kg	Euro
new 402.67.06.115	SK 40	AD	EPC (3 - 6)	3-4-5-6	4	2,50	
new 402.67.08.115	SK 40	AD	EPC (3 - 8)	3-4-5-6-8	5	2,63	
new 402.67.12.140	SK 40	AD	EPC (3 - 12)	6-8-10-12	5	2,84	
new 402.67.16.140	SK 40	AD	EPC (3 - 16)	6-8-10-12-16	5	3,20	
new 502.67.06.115	SK 50	AD	EPC (3 - 6)	3-4-5-6	4	4,31	
new 502.67.08.115	SK 50	AD	EPC (3 - 8)	3-4-5-6-8	5	4,45	
new 502.67.12.140	SK 50	AD	EPC (3 - 12)	6-8-10-12	5	4,66	
new 502.67.16.140	SK 50	AD	EPC (3 - 16)	6-8-10-12-16	5	5,02	



Lieferumfang : Spannfutter, inkl. Spannzangen mit Schlüssel
Included : Collet chuck with collets and wrench
Inclus : Mandrin avec pinces et clé
Teslim Şekli : Tutucu, pensleri ve anahtarıyla birlikte

Zubehör / Accessories / Accessoires / Yedekler

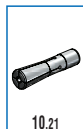

Spannzangen
Collets
Pinces de serrage
Pens



Spannschlüssel
Wrench
Clé de serrage
Sıkma anahtarı





Morsekegel-Aufnahmen mit Austreibblappen

Morse taper adaptor

Douilles intermédiaires pour outils à cône Morse

Mors adaptörü

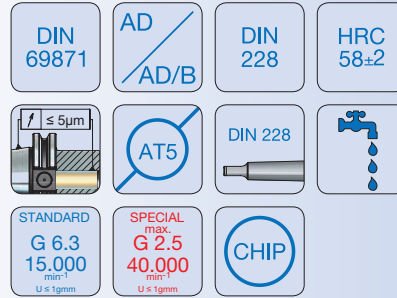

Bestell-Nr. Order Nr. Reference Sipariş Nr.	SK	Form	MK	A	D	Kg	Euro
302.07.01.50	SK 30	AD	MK 1	50	25	0,44	
302.07.02.65	SK 30	AD	MK 2	65	32	0,53	
302.07.03.80	SK 30	AD	MK 3	80	40	0,68	
402.07.01.50	SK 40	AD	MK 1	50	25	0,87	
403.07.01.50	SK 40	AD/B	MK 1	50	25	0,97	
402.07.02.50	SK 40	AD	MK 2	50	32	0,88	
403.07.02.50	SK 40	AD/B	MK 2	50	32	0,94	
402.07.02.117	SK 40	AD	MK 2	117	32	1,27	
402.07.03.70	SK 40	AD	MK 3	70	40	1,03	
403.07.03.70	SK 40	AD/B	MK 3	70	40	1,02	
402.07.03.133	SK 40	AD	MK 3	133	40	1,61	
402.07.04.95	SK 40	AD	MK 4	95	48	1,26	
403.07.04.95	SK 40	AD/B	MK 4	95	48	1,25	
402.07.04.156	SK 40	AD	MK 4	156	48	2,06	
502.07.01.45	SK 50	AD	MK 1	45	25	2,61	
503.07.01.45	SK 50	AD/B	MK 1	45	25	3,11	
502.07.02.60	SK 50	AD	MK 2	60	32	2,69	
503.07.02.60	SK 50	AD/B	MK 2	60	32	3,25	
502.07.02.117	SK 50	AD	MK 2	117	32	3,06	
502.07.03.65	SK 50	AD	MK 3	65	40	2,72	
503.07.03.65	SK 50	AD/B	MK 3	65	40	3,09	
502.07.03.137	SK 50	AD	MK 3	137	40	3,40	
502.07.04.95	SK 50	AD	MK 4	95	48	3,01	
503.07.04.95	SK 50	AD/B	MK 4	95	48	3,19	
502.07.04.167	SK 50	AD	MK 4	167	48	3,97	
502.07.05.105	SK 50	AD	MK 5	105	63	3,18	
503.07.05.105	SK 50	AD/B	MK 5	105	63	3,22	
502.07.05.197	SK 50	AD	MK 5	197	63	5,19	

FORM AD

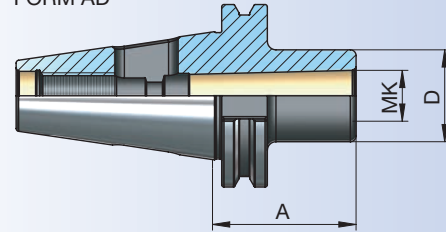

FORM AD/B

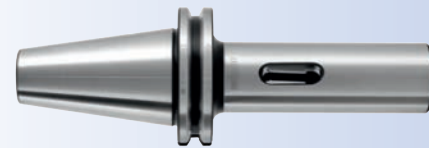
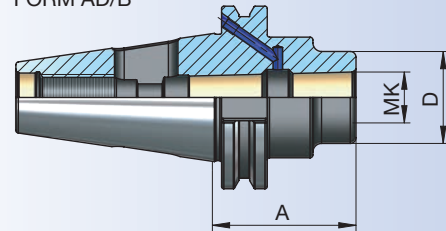



Zwischenhülsen für MK mit Anzugsgewinde

Morse taper adaptor for tools with morse taper shank and drawbar thread

Douilles intermédiaires pour outils à cône Morse à trou fileté

Mors adaptörü çektirme civatalı

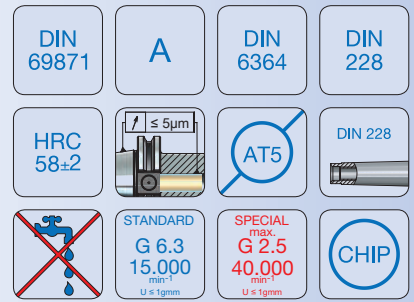

Bestell-Nr. Order Nr. Reference Sipariş Nr.	SK	Form	MK	A	D	Kg	Euro
402.08.01.50	SK 40	A	MK 1	50	25	0,91	
402.08.02.50	SK 40	A	MK 2	50	32	0,93	
402.08.03.70	SK 40	A	MK 3	70	40	1,10	
402.08.04.95	SK 40	A	MK 4	95	48	1,39	
*402.08.04A.110	SK 40	A	MK 4	110	63	2,20	

502.08.01.45	SK 50	A	MK 1	45	25	2,71	
502.08.02.60	SK 50	A	MK 2	60	32	2,80	
502.08.03.65	SK 50	A	MK 3	65	40	2,89	
502.08.04.70	SK 50	A	MK 4	70	48	2,92	
*502.08.04A.85	SK 50	A	MK 4	85	63	3,61	
502.08.05.100	SK 50	A	MK 5	100	63	3,32	
*502.08.05A.118	SK 50	A	MK 5	118	78	4,63	

* Mit Mitnahmeausfräsung nach DIN 2201

* With driving facilities to DIN 2201

* Avec douille d'accouplement de fraisure DIN 2201

* Taşıyıcı yuvalı DIN 2201

FORM A

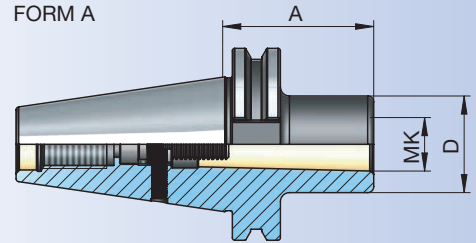

Adapter / Reduzierungen

Reduction Sleeves

Douilles de réduction

Çektirme civatalı redüksiyon

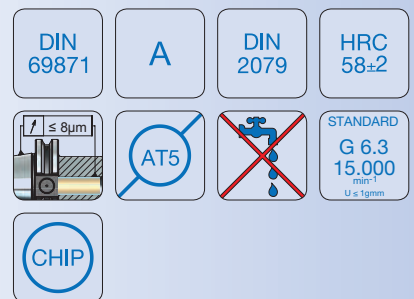

Bestell-Nr. Order Nr. Reference Sipariş Nr.	SK	Form	SK ₁	A	D	Kg	Euro
402.09.30.50	SK 40	A	SK 30	50	50	1,10	
402.09.40.100	SK 40	A	SK 40	100	63	2,10	
502.09.40.70	SK 50	A	SK 40	70	70	3,68	
502.09.50.120	SK 50	A	SK 50	120	97	5,97	

FORM A

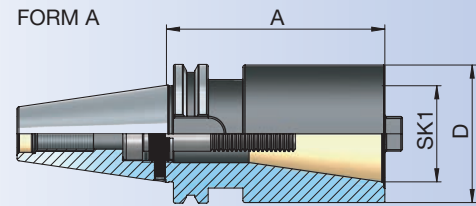



Kombi - Aufsteckfräserdorne

Combi shell mill holder

Porte-fraises á double usage pour fraises á entraînement par clavette ou tenon

Kombine malafa

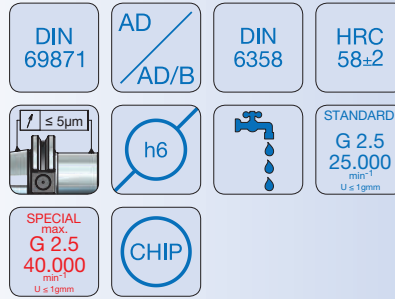

Bestell-Nr. Order Nr. Reference Sipariş Nr.	SK	Form	d	A	D	D1	L1	L3	L4	Kg	Euro
302.10.16.50	SK 30	AD	16	50	32	-	-	17	27	0,60	
302.10.22.50	SK 30	AD	22	50	40	-	-	19	31	0,74	
302.10.27.55	SK 30	AD	27	55	48	-	-	21	33	0,94	
302.10.32.60	SK 30	AD	32	60	58	-	-	24	38	1,22	
402.10.16.55	SK 40	AD	16	55	32	-	-	17	27	1,06	
403.10.16.55	SK 40	AD/B	16	55	32	-	-	17	27	1,05	
402.10.16.100	SK 40	AD	16	100	32	-	-	17	27	1,32	
403.10.16.100	SK 40	AD/B	16	100	32	-	-	17	27	1,32	
402.10.16.130	SK 40	AD	16	130	32	-	-	17	27	1,50	
403.10.16.130	SK 40	AD/B	16	130	32	-	-	17	27	1,49	
402.10.16.160	SK 40	AD	16	160	32	39	88	17	27	1,78	
403.10.16.160	SK 40	AD/B	16	160	32	39	88	17	27	1,77	
403.10.16.200	SK 40	AD/B	16	200	32	40	120	17	27	2,03	
402.10.22.55	SK 40	AD	22	55	40	-	-	19	31	1,20	
403.10.22.55	SK 40	AD/B	22	55	40	-	-	19	31	1,19	
402.10.22.100	SK 40	AD	22	100	40	-	-	19	31	1,60	
403.10.22.100	SK 40	AD/B	22	100	40	-	-	19	31	1,59	
402.10.22.130	SK 40	AD	22	130	40	-	-	19	31	1,87	
403.10.22.130	SK 40	AD/B	22	130	40	-	-	19	31	1,86	
402.10.22.160	SK 40	AD	22	160	40	47,5	88	19	31	2,28	
403.10.22.160	SK 40	AD/B	22	160	40	47,5	88	19	31	2,27	
403.10.22.200	SK 40	AD/B	22	200	40	48,5	120	19	31	2,66	

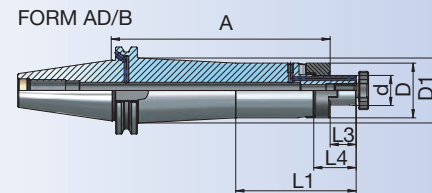
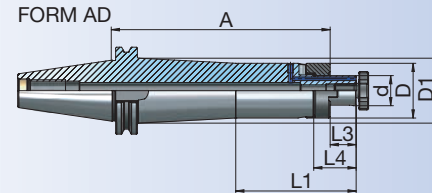

Zubehör / Accessories / Accessoires / Yedekler



Mitnehmerringe
Clutch drive rings to
Bague d'entraînement
Tirmaklı pul



Fräseranzugsschrauben
Drawn in bolt
Vis de serrage
Alın sıkma civatası



Paßfeder
Drive key
Ressort de passage
Kama



Spannschlüssel für Aufsteckdorne
Wrench
Clé de serrage
Alın civatası sıkma anahtar



Kombi - Aufsteckfräserdorne

Combi shell mill holder

Porte-fraises à double usage pour fraises à entraînement par clavette ou tenon

Kombine malafa

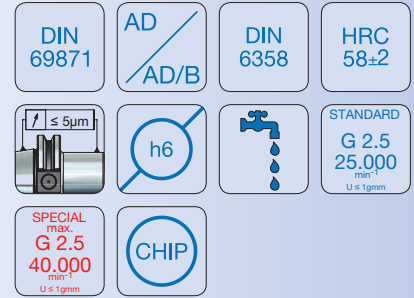

Bestell-Nr. Order Nr. Reference Sipariş Nr.	SK	Form	d	A	D	D1	L1	L3	L4	Kg	Euro
402.10.27.55	SK 40	AD	27	55	48	-	-	21	33	1,40	
403.10.27.55	SK 40	AD/B	27	55	48	-	-	21	33	1,39	
402.10.27.100	SK 40	AD	27	100	48	-	-	21	33	2,00	
403.10.27.100	SK 40	AD/B	27	100	48	-	-	21	33	1,98	
402.10.27.130	SK 40	AD	27	130	48	-	-	21	33	2,39	
403.10.27.130	SK 40	AD/B	27	130	48	-	-	21	33	2,38	
402.10.27.160	SK 40	AD	27	160	48	-	-	21	33	2,79	
403.10.27.160	SK 40	AD/B	27	160	48	-	-	21	33	2,78	
403.10.27.200	SK 40	AD/B	27	200	48	-	-	21	33	3,30	
402.10.32.60	SK 40	AD	32	60	58	-	-	24	38	1,71	
403.10.32.60	SK 40	AD/B	32	60	58	-	-	24	38	1,69	
402.10.32.100	SK 40	AD	32	100	58	-	-	24	38	2,51	
403.10.32.100	SK 40	AD/B	32	100	58	-	-	24	38	2,48	
402.10.32.130	SK 40	AD	32	130	58	-	-	24	38	3,10	
403.10.32.130	SK 40	AD/B	32	130	58	-	-	24	38	3,08	
402.10.32.160	SK 40	AD	32	160	58	-	-	24	38	3,69	
403.10.32.160	SK 40	AD/B	32	160	58	-	-	24	38	3,67	
403.10.32.200	SK 40	AD/B	32	200	58	-	-	24	38	4,46	
402.10.40.60	SK 40	AD	40	60	70	-	-	27	41	2,11	
403.10.40.60	SK 40	AD/B	40	60	70	-	-	27	41	2,08	

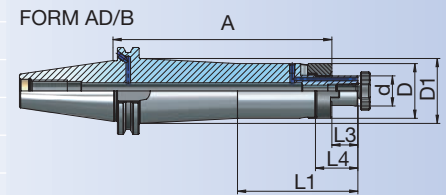
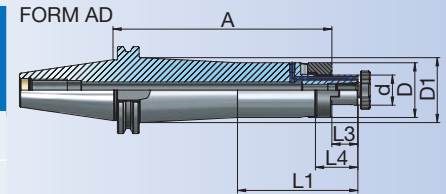

Zubehör / Accessories / Accessoires / Yedekler

DIN 6366



10.46

Mitnehmerringe
Clutch drive rings to
Bague d'entraînement
Tırnaklı pul

DIN 6367



10.45

Fräseranzugsschrauben
Drawn in bolt
Vis de serrage
Alın sıkma civatası

DIN 6885



10.44

Paßfeder
Drive key
Ressort de passage
Kama

DIN 6388



10.46

Spannschlüssel für Aufsteckdorne
Wrench
Clé de serrage
Alın civatası sıkma anahtarı



Kombi - Aufsteckfräserdorne

Combi shell mill holder

Porte-fraises á double usage pour fraises á entraînement par clavette ou tenon

Kombine malafa

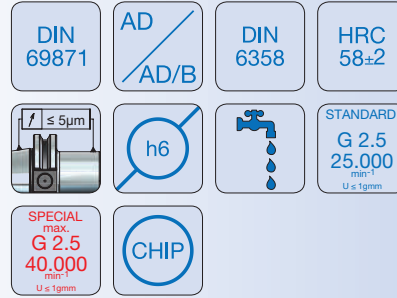

Bestell-Nr. Order Nr. Reference Sipariş Nr.	SK	Form	d	A	D	D1	L1	L3	L4	Kg	Euro
502.10.16.55	SK 50	AD	16	55	32	-	-	17	27	2,88	
503.10.16.55	SK 50	AD/B	16	55	32	-	-	17	27	2,86	
502.10.16.100	SK 50	AD	16	100	32	-	-	17	27	3,14	
503.10.16.100	SK 50	AD/B	16	100	32	-	-	17	27	3,13	
502.10.16.130	SK 50	AD	16	130	32	-	-	17	27	3,33	
503.10.16.130	SK 50	AD/B	16	130	32	-	-	17	27	3,31	
502.10.16.160	SK 50	AD	16	160	32	38,5	88	17	27	3,62	
503.10.16.160	SK 50	AD/B	16	160	32	38,5	88	17	27	3,60	
503.10.16.200	SK 50	AD/B	16	200	32	39	120	17	27	3,89	
502.10.22.55	SK 50	AD	22	55	40	-	-	19	31	3,02	
503.10.22.55	SK 50	AD/B	22	55	40	-	-	19	31	3,00	
502.10.22.100	SK 50	AD	22	100	40	-	-	19	31	3,42	
503.10.22.100	SK 50	AD/B	22	100	40	-	-	19	31	3,40	
502.10.22.130	SK 50	AD	22	130	40	-	-	19	31	3,70	
503.10.22.130	SK 50	AD/B	22	130	40	-	-	19	31	3,68	
502.10.22.160	SK 50	AD	22	160	40	47	88	19	31	4,11	
503.10.22.160	SK 50	AD/B	22	160	40	47	88	19	31	4,09	
503.10.22.200	SK 50	AD/B	22	200	40	47,5	120	19	31	4,48	
502.10.27.55	SK 50	AD	27	55	48	-	-	21	33	3,22	
503.10.27.55	SK 50	AD/B	27	55	48	-	-	21	33	3,20	
502.10.27.100	SK 50	AD	27	100	48	-	-	21	33	3,82	
503.10.27.100	SK 50	AD/B	27	100	48	-	-	21	33	3,79	
502.10.27.130	SK 50	AD	27	130	48	-	-	21	33	4,23	
503.10.27.130	SK 50	AD/B	27	130	48	-	-	21	33	4,21	
502.10.27.160	SK 50	AD	27	160	48	55	88	21	33	4,81	
503.10.27.160	SK 50	AD/B	27	160	48	55	88	21	33	4,79	
503.10.27.200	SK 50	AD/B	27	200	48	56	120	21	33	5,36	

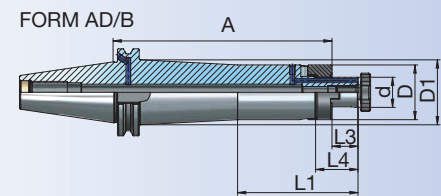
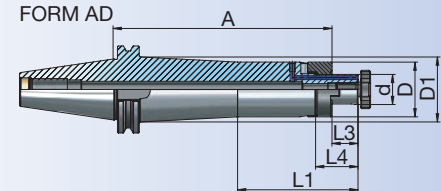

Zubehör / Accessories / Accessoires / Yedekler



Mitnehmerringe
Clutch drive rings to
Bague d'entraînement
Tırnaklı pul



Fräseranzugsschrauben
Drawn in bolt
Vis de serrage
Alın sıkma civatası



Paßfeder
Drive key
Ressort de passage
Kama



Spannschlüssel für Aufsteckdorne
Wrench
Clé de serrage
Alın civatası sıkma anahtarı



Kombi - Aufsteckfräserdorne

Combi shell mill holder

Porte-fraises á double usage pour fraises á entraînement par clavette ou tenon

Kombine malafa

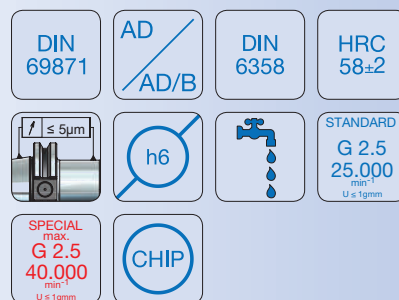

Bestell-Nr. Order Nr. Reference Sipariş Nr.	SK	Form	d	A	D	D1	L1	L3	L4	Kg	Euro
502.10.32.55	SK 50	AD	32	55	58	-	-	24	38	3,53	
503.10.32.55	SK 50	AD/B	32	55	58	-	-	24	38	3,50	
502.10.32.100	SK 50	AD	32	100	58	-	-	24	38	4,42	
503.10.32.100	SK 50	AD/B	32	100	58	-	-	24	38	4,39	
502.10.32.130	SK 50	AD	32	130	58	-	-	24	38	5,01	
503.10.32.130	SK 50	AD/B	32	130	58	-	-	24	38	4,98	
502.10.32.160	SK 50	AD	32	160	58	66	88	24	38	5,83	
503.10.32.160	SK 50	AD/B	32	160	58	66	88	24	38	5,80	
503.10.32.200	SK 50	AD/B	32	200	58	66,5	120	24	38	6,64	
502.10.40.55	SK 50	AD	40	55	70	-	-	27	41	4,01	
503.10.40.55	SK 50	AD/B	40	55	70	-	-	27	41	3,97	
502.10.40.100	SK 50	AD	40	100	70	-	-	27	41	5,33	
503.10.40.100	SK 50	AD/B	40	100	70	-	-	27	41	5,29	
502.10.40.130	SK 50	AD	40	130	70	-	-	27	41	6,20	
503.10.40.130	SK 50	AD/B	40	130	70	-	-	27	41	6,16	
502.10.40.160	SK 50	AD	40	160	70	-	-	27	41	7,07	
503.10.40.160	SK 50	AD/B	40	160	70	-	-	27	41	7,03	
503.10.40.200	SK 50	AD/B	40	200	70	-	-	27	41	8,20	

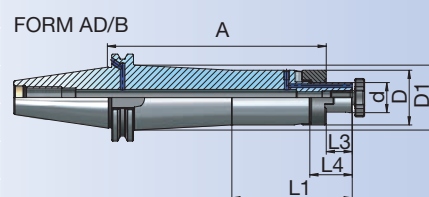
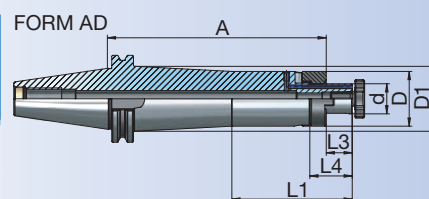

Zubehör / Accessories / Accessoires / Yedekler



Mitnehmerringe
Clutch drive rings to
Bague d'entraînement
Tirmaklı pul



Fräseranzugsschrauben
Drawn in bolt
Vis de serrage
Alın sıkma civatası



Paßfeder
Drive key
Ressort de passage
Kama



Spannschlüssel für Aufsteckdorne
Wrench
Clé de serrage
Alın civatası sıkma anahtarı



Quernut-Aufsteckdorne mit vergrößertem Bunddurchmesser

Shell mill holder for cutters with driving slot

Porte-fraises à surfacer avec diamètre de collerette élargi

Alın kamalı malafa

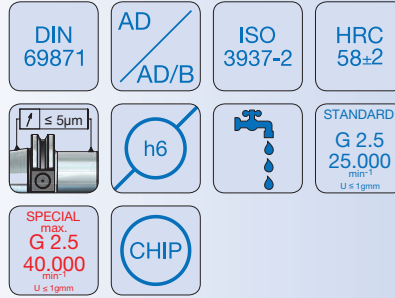

Bestell-Nr. Order Nr. Reference Sipariş Nr.	SK	Form	d	A	D	D1	L1	L3	Kg	Euro
302.11.16.40	SK 30	AD	16	40	38	-	-	17	0,60	
302.11.22.40	SK 30	AD	22	40	45	-	-	19	0,71	
302.11.27.50	SK 30	AD	27	50	60	-	-	21	1,00	
302.11.32.50	SK 30	AD	32	50	78	-	-	24	1,35	
402.11.16.35	SK 40	AD	16	35	38	-	-	17	1,01	
403.11.16.35	SK 40	AD/B	16	35	38	-	-	17	0,98	
402.11.16.100	SK 40	AD	16	100	38	-	-	17	1,59	
403.11.16.100	SK 40	AD/B	16	100	38	-	-	17	1,53	
402.11.16.130	SK 40	AD	16	130	38	-	-	17	1,85	
403.11.16.130	SK 40	AD/B	16	130	38	-	-	17	1,78	
402.11.16.160	SK 40	AD	16	160	38	45,5	88	17	2,24	
403.11.16.160	SK 40	AD/B	16	160	38	45,5	88	17	2,16	
402.11.16.200	SK 40	AD	16	200	38	46,5	120	17	2,62	
new 403.11.16.200	SK 40	AD/B	16	200	38	46,5	120	17	2,60	
402.11.22.35	SK 40	AD	22	35	48	-	-	19	1,13	
403.11.22.35	SK 40	AD/B	22	35	48	-	-	19	1,09	
402.11.22.100	SK 40	AD	22	100	48	-	-	19	2,05	
403.11.22.100	SK 40	AD/B	22	100	48	-	-	19	1,95	
402.11.22.130	SK 40	AD	22	130	48	-	-	19	2,47	
403.11.22.130	SK 40	AD/B	22	130	48	-	-	19	2,34	
402.11.22.160	SK 40	AD	22	160	48	-	-	19	2,89	
403.11.22.160	SK 40	AD/B	22	160	48	-	-	19	2,74	
402.11.22.200	SK 40	AD	22	200	48	-	-	19	3,46	
new 403.11.22.200	SK 40	AD/B	22	200	48	-	-	19	3,40	

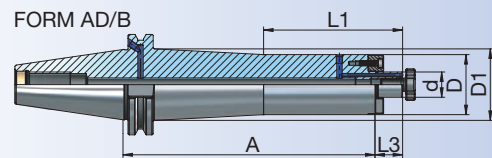
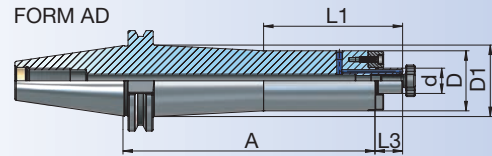

Zubehör / Accessories / Accessoires / Yedekler

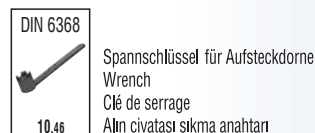



Quernut-Aufsteckdorne mit vergrößertem Bunddurchmesser

Shell mill holder for cutters with driving slot

Porte-fraises à surfer avec diamètre de collerette élargi

Alın kamalı malafa

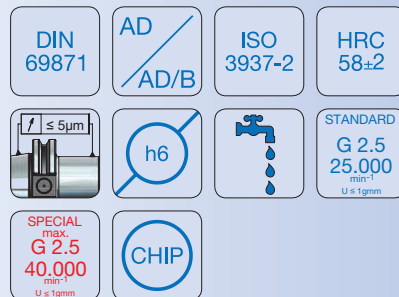

Bestell-Nr. Order Nr. Reference Sipariş Nr.	SK	Form	d	A	D	D1	L1	L3	Kg	Euro
402.11.27.45	SK 40	AD	27	45	60	-	-	21	1,42	
403.11.27.45	SK 40	AD/B	27	45	60	-	-	21	1,37	
402.11.27.100	SK 40	AD	27	100	60	-	-	21	2,64	
403.11.27.100	SK 40	AD/B	27	100	60	-	-	21	2,53	
402.11.27.130	SK 40	AD	27	130	60	-	-	21	3,30	
403.11.27.130	SK 40	AD/B	27	130	60	-	-	21	3,17	
402.11.27.160	SK 40	AD	27	160	60	-	-	21	3,96	
403.11.27.160	SK 40	AD/B	27	160	60	-	-	21	3,80	
402.11.27.200	SK 40	AD	27	200	60	-	-	21	4,84	
new 403.11.27.200	SK 40	AD/B	27	200	60	-	-	21	4,80	
402.11.32.50	SK 40	AD	32	50	78	-	-	24	1,85	
403.11.32.50	SK 40	AD/B	32	50	78	-	-	24	1,79	
402.11.32.100	SK 40	AD	32	100	78	-	-	24	2,84	
403.11.32.100	SK 40	AD/B	32	100	78	-	-	24	2,73	
402.11.32.130	SK 40	AD	32	130	78	-	-	24	3,30	
403.11.32.130	SK 40	AD/B	32	130	78	-	-	24	3,16	
402.11.32.160	SK 40	AD	32	160	78	-	-	24	3,75	
403.11.32.160	SK 40	AD/B	32	160	78	-	-	24	3,59	
402.11.32.200	SK 40	AD	32	200	78	-	-	24	4,36	
new 403.11.32.200	SK 40	AD/B	32	200	78	-	-	24	4,30	
*402.11.40.50	SK 40	AD	40	50	88	-	-	27	2,12	
*403.11.40.50	SK 40	AD/B	40	50	88	-	-	27	2,06	

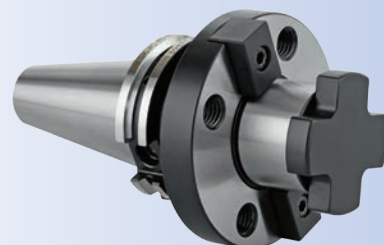
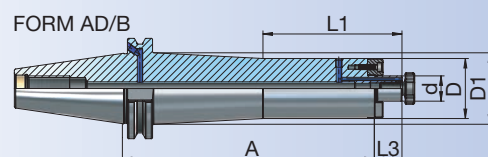
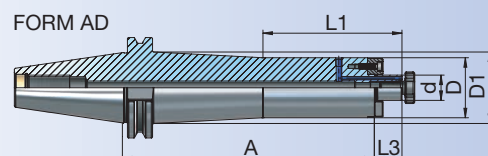

*d=Ø 40 (M12)

Mit zusätzlichen 4 Gewindebohrungen nach DIN 2079
With additional 4 screws holes in compliance with DIN 2079
Avec 4 trous taraudés supplémentaires d'après DIN 2079
DIN 2079 'a uygun ilave 4 vida bağlantılı

Zubehör / Accessories / Accessoires / Yedekler



Fräseranzugsschrauben
Drawn in bolt
Vis de serrage
Alın sıkma civatası



Mitnehmersteine
Drive keys
Entraîneur
Kama



Spannschlüssel für Aufsteckdorne
Wrench
Clé de serrage
Alın civatası sıkma anahtarı



Quernut-Aufsteckdorne mit vergrößertem Bunddurchmesser

Shell mill holder for cutters with driving slot

Porte-fraises à surfacer avec diamètre de collerette élargi

Alın kamalı malafa

DIN 69871	AD / AD/B	ISO 3937-2	HRC 58±2
$7 \leq 5\mu\text{m}$	h6		STANDARD G 2.5 25.000 min ⁻¹ U ≤ 1gmm
SPECIAL max G 2.5 40.000 min ⁻¹ U ≤ 1gmm	CHIP		

Bestell-Nr. Order Nr. Reference Sipariş Nr.	SK	Form	d	A	D	D1	L1	L3	Kg	Euro
502.11.16.35	SK 50	AD	16	35	38	-	-	17	2,84	
503.11.16.35	SK 50	AD/B	16	35	38	-	-	17	2,79	
502.11.16.100	SK 50	AD	16	100	38	-	-	17	3,41	
503.11.16.100	SK 50	AD/B	16	100	38	-	-	17	3,34	
502.11.16.130	SK 50	AD	16	130	38	-	-	17	3,69	
503.11.16.130	SK 50	AD/B	16	130	38	-	-	17	3,61	
502.11.16.160	SK 50	AD	16	160	38	44,5	88	17	4,09	
503.11.16.160	SK 50	AD/B	16	160	38	44,5	88	17	3,99	
502.11.16.200	SK 50	AD	16	200	38	45	120	17	4,50	
new 503.11.16.200	SK 50	AD/B	16	200	38	45	120	17	4,45	
502.11.22.35	SK 50	AD	22	35	48	-	-	19	2,96	
503.11.22.35	SK 50	AD/B	22	35	48	-	-	19	2,90	
502.11.22.100	SK 50	AD	22	100	48	-	-	19	3,88	
503.11.22.100	SK 50	AD/B	22	100	48	-	-	19	3,76	
502.11.22.130	SK 50	AD	22	130	48	-	-	19	4,32	
503.11.22.130	SK 50	AD/B	22	130	48	-	-	19	4,17	
502.11.22.160	SK 50	AD	22	160	48	55	88	19	4,91	
503.11.22.160	SK 50	AD/B	22	160	48	55	88	19	4,74	
502.11.22.200	SK 50	AD	22	200	48	55,5	120	19	5,52	
new 503.11.22.200	SK 50	AD/B	22	200	48	55,5	120	19	5,48	
502.11.27.40	SK 50	AD	27	40	60	-	-	21	3,26	
503.11.27.40	SK 50	AD/B	27	40	60	-	-	21	3,19	
502.11.27.100	SK 50	AD	27	100	60	-	-	21	4,58	
503.11.27.100	SK 50	AD/B	27	100	60	-	-	21	4,46	
502.11.27.130	SK 50	AD	27	130	60	-	-	21	5,24	
503.11.27.130	SK 50	AD/B	27	130	60	-	-	21	5,09	
502.11.27.160	SK 50	AD	27	160	60	67,5	88	21	6,12	
503.11.27.160	SK 50	AD/B	27	160	60	67,5	88	21	5,95	
502.11.27.200	SK 50	AD	27	200	60	68,5	120	21	7,05	
new 503.11.27.200	SK 50	AD/B	27	200	60	68,5	120	21	7,00	

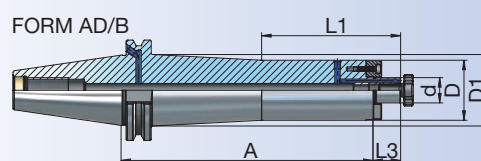
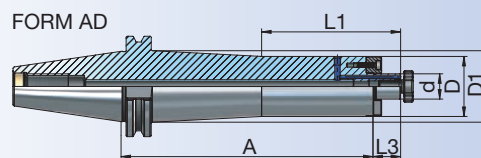

Zubehör / Accessories / Accessoires / Yedekler

DIN 6367

 Fräseranzugsschrauben
 Drawn in bolt
 Vis de serrage
 Alın sıkma civatası
 10.45

10.44

 Mitnehmersteine
 Drive keys
 Entraîneur
 Kama

DIN 6368

 Spanschlüssel für Aufsteckdorne
 Wrench
 Clé de serrage
 Alın civatası sıkma anahtarı
 10.46



Quernut-Aufsteckdorne mit vergrößertem Bunddurchmesser

Shell mill holder for cutters with driving slot

Porte-fraises à surfacer avec diamètre de collerette élargi

Alın kamalı malafa

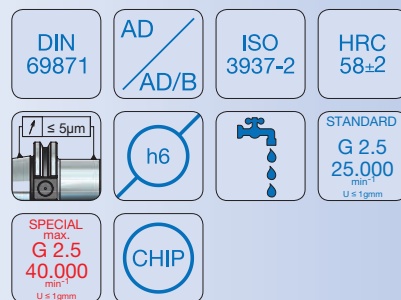

Bestell-Nr. Order Nr. Reference Sipariş Nr.	SK	Form	d	A	D	D1	L1	L3	Kg	Euro
502.11.32.50	SK 50	AD	32	50	78	-	-	24	4,02	
503.11.32.50	SK 50	AD/B	32	50	78	-	-	24	3,93	
502.11.32.100	SK 50	AD	32	100	78	-	-	24	5,88	
503.11.32.100	SK 50	AD/B	32	100	78	-	-	24	5,75	
502.11.32.130	SK 50	AD	32	130	78	-	-	24	7,00	
503.11.32.130	SK 50	AD/B	32	130	78	-	-	24	6,84	
502.11.32.160	SK 50	AD	32	160	78	-	-	24	8,12	
503.11.32.160	SK 50	AD/B	32	160	78	-	-	24	7,93	
502.11.32.200	SK 50	AD	32	200	78	-	-	24	9,61	
new 503.11.32.200	SK 50	AD/B	32	200	78	-	-	24	9,58	
*502.11.40.50	SK 50	AD	40	50	88	-	-	27	4,28	
*503.11.40.50	SK 50	AD/B	40	50	88	-	-	27	4,19	
*502.11.40.100	SK 50	AD	40	100	88	-	-	27	6,65	
*503.11.40.100	SK 50	AD/B	40	100	88	-	-	27	6,52	
*502.11.40.130	SK 50	AD	40	130	88	-	-	27	8,08	
*503.11.40.130	SK 50	AD/B	40	130	88	-	-	27	7,91	
*502.11.40.160	SK 50	AD	40	160	88	-	-	27	9,50	
*503.11.40.160	SK 50	AD/B	40	160	88	-	-	27	9,31	
*502.11.40.200	SK 50	AD	40	200	88	-	-	27	11,40	
new *503.11.40.200	SK 50	AD/B	40	200	88	-	-	27	11,35	
new 502.11.50.70	SK 50	AD	50	70	118	-	-	30	6,84	
503.11.50.70	SK 50	AD/B	50	70	118	-	-	30	6,81	
*502.11.60.70	SK 50	AD	60	70	128	-	-	40	7,63	
*503.11.60.70	SK 50	AD/B	60	70	128	-	-	40	7,50	

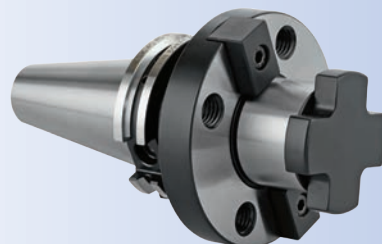
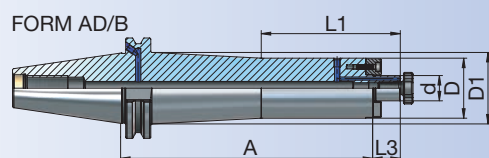
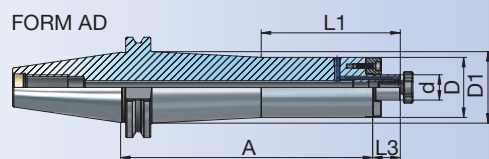

* d=∅ 40 (M12) * d=∅ 60 (M16)

Mit zusätzlichen 4 Gewindebohrungen nach DIN 2079
With additional 4 screws holes in compliance with DIN 2079
Avec 4 trous taraudés supplémentaires d'après DIN 2079
DIN 2079'a uygun ilave 4 vida bağlantılı

Zubehör / Accessories / Accessoires / Yedekler



Fräseranzugsschrauben
Drawn in bolt
Vis de serrage
Alın sıkma civatası



Mitnehmersteine
Drive keys
Entraîneur
Kama



Spannschlüssel für Aufsteckdorne
Wrench
Clé de serrage
Alın civatası sıkma anahtarı



Fräseraufnahmen für Einschraubfräser

Milling Cutter Arbors for Screw-on type Milling Cutters

Axes Coupeur Fraisage Pour Vis-Sur Type Coupeurs de Fraisage

Vidalı tip frezeler için takım tutucular

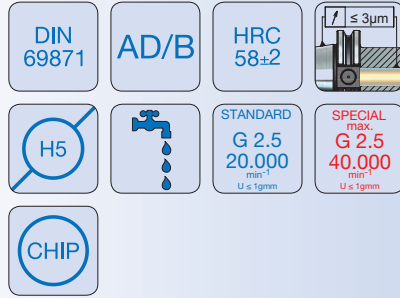

Bestell-Nr. Order Nr. Reference Sipariş Nr.	SK	Form	M	A	d	D	D1	Kg	Euro
403.12.06.44	SK 40	AD/B	M6	44	6,5	10	13	0,80	
403.12.06.69	SK 40	AD/B	M6	69	6,5	10	19,5	0,85	
403.12.06.94	SK 40	AD/B	M6	94	6,5	10	22,5	0,90	
403.12.08.44	SK 40	AD/B	M8	44	8,5	13	15	0,81	
403.12.08.69	SK 40	AD/B	M8	69	8,5	13	22,5	0,87	
403.12.08.94	SK 40	AD/B	M8	94	8,5	13	23	0,92	
403.12.08.119	SK 40	AD/B	M8	119	8,5	13	25	0,99	
403.12.10.24	SK 40	AD/B	M10	24	10,5	18	-	0,81	
403.12.10.44	SK 40	AD/B	M10	44	10,5	18	20	0,83	
403.12.10.69	SK 40	AD/B	M10	69	10,5	18	22,5	0,90	
403.12.10.94	SK 40	AD/B	M10	94	10,5	18	27,5	1,00	
403.12.10.119	SK 40	AD/B	M10	119	10,5	18	32	1,14	
403.12.10.169	SK 40	AD/B	M10	169	10,5	18	36	1,44	
403.12.12.24	SK 40	AD/B	M12	24	12,5	21	-	0,80	
403.12.12.44	SK 40	AD/B	M12	44	12,5	21	24	0,84	
403.12.12.69	SK 40	AD/B	M12	69	12,5	21	24	0,91	
403.12.12.94	SK 40	AD/B	M12	94	12,5	21	31	1,06	
403.12.12.119	SK 40	AD/B	M12	119	12,5	21	33	1,19	
403.12.12.144	SK 40	AD/B	M12	144	12,5	21	35,5	1,37	
403.12.12.169	SK 40	AD/B	M12	169	12,5	21	39,5	1,61	
403.12.16.24	SK 40	AD/B	M16	24	17	29	-	0,78	
403.12.16.44	SK 40	AD/B	M16	44	17	29	-	0,87	
403.12.16.69	SK 40	AD/B	M16	69	17	29	34	1,03	
403.12.16.94	SK 40	AD/B	M16	94	17	29	34	1,18	
403.12.16.119	SK 40	AD/B	M16	119	17	29	36	1,36	
403.12.16.144	SK 40	AD/B	M16	144	17	29	40	1,62	
403.12.16.169	SK 40	AD/B	M16	169	17	29	42,5	1,88	

FORM AD/B

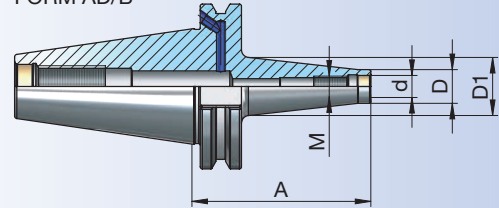

Empfohlene Anzugsmomente Recommended tightening torques Torques de serrage recommandés Önerilen sıkma torku	
M6	10 Nm
M8	25 Nm
M10	40 Nm
M12	60 Nm
M16	80 Nm

Zubehör / Accessories / Accessoires / Yedekler

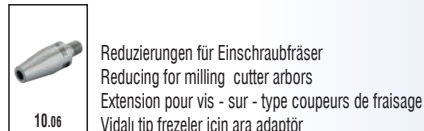
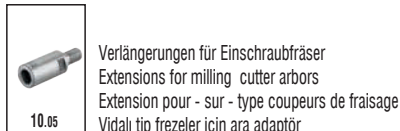



Fräseraufnahmen für Einschraubfräser

Milling Cutter Arbors for Screw-on type Milling Cutters

Axes Coupeur Fraisage Pour Vis-Sur Type Coupeurs de Fraisage

Vidalı tip frezeler için takım tutucular

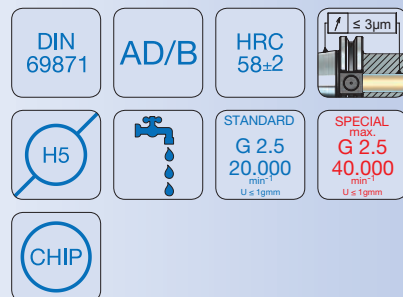

Bestell-Nr. Order Nr. Reference Sipariş Nr.	SK	Form	M	A	d	D	D1	Kg	Euro
503.12.08.69	SK 50	AD/B	M8	69	8,5	13	22,5	2,67	
503.12.08.119	SK 50	AD/B	M8	119	8,5	13	25	2,78	
503.12.08.169	SK 50	AD/B	M8	169	8,5	13	29,5	2,99	
503.12.10.69	SK 50	AD/B	M10	69	10,5	18	23	2,70	
503.12.10.119	SK 50	AD/B	M10	119	10,5	18	32	2,93	
503.12.10.169	SK 50	AD/B	M10	169	10,5	18	36	3,23	
503.12.12.69	SK 50	AD/B	M12	69	12,5	21	24	2,71	
503.12.12.119	SK 50	AD/B	M12	119	12,5	21	33	2,99	
503.12.12.169	SK 50	AD/B	M12	169	12,5	21	39,5	3,39	
503.12.16.69	SK 50	AD/B	M16	69	17	29	34	2,83	
503.12.16.119	SK 50	AD/B	M16	119	17	29	36	3,16	
503.12.16.169	SK 50	AD/B	M16	169	17	29	42,5	3,68	

FORM AD/B

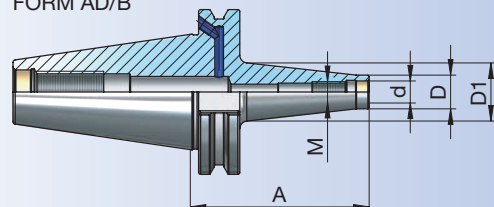

Empfohlene Anzugsmomente Recommended tightening torques Torques de serrage recommandés Önerilen sıkma torku

M6	10 Nm
M8	25 Nm
M10	40 Nm
M12	60 Nm
M16	80 Nm

Zubehör / Accessories / Accessoires / Yedekler



Verlängerungen für Einschraubfräser
Extensions for milling cutter arbors
Extension pour vis-sur-type coupeurs de fraisage
Vidalı tip frezeler için ara adaptör



Reduzierungen für Einschraubfräser
Reducing for milling cutter arbors
Extension pour vis-sur-type coupeurs de fraisage
Vidalı tip frezeler için ara adaptör



Fräseraufnahmen für Einschraubfräser, schlanke Ausführung

Milling Cutter Arbors for Screw-on type Milling Cutters,
slimline design

Axes Coupeur Fraisage Pour Vis-Sur Type Coupeurs de Fraisage,
design mince

Vidalı tip frezeler için takım tutucular, ince cidarlı

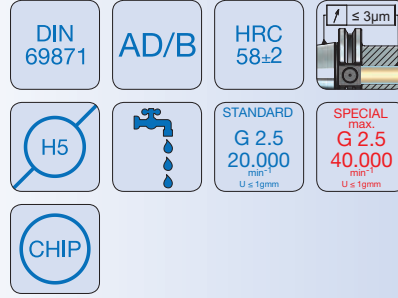

Bestell-Nr. Order Nr. Reference Sipariş Nr.	SK	Form	M	A	d	D	L	Kg	Euro
403.12.10.119.S	SK 40	AD/B	M10	119	10,5	18	100	0,97	
403.12.10.169.S	SK 40	AD/B	M10	169	10,5	18	150	1,05	
403.12.12.119.S	SK 40	AD/B	M12	119	12,5	21	100	1,03	
403.12.12.144.S	SK 40	AD/B	M12	144	12,5	21	125	1,09	
403.12.12.169.S	SK 40	AD/B	M12	169	12,5	21	150	1,15	
403.12.16.119.S	SK 40	AD/B	M16	119	17	29	100	1,24	
403.12.16.144.S	SK 40	AD/B	M16	144	17	29	125	1,36	
403.12.16.169.S	SK 40	AD/B	M16	169	17	29	150	1,48	

503.12.10.119.S	SK 50	AD/B	M10	119	10,5	18	100	2,77	
503.12.10.169.S	SK 50	AD/B	M10	169	10,5	18	150	2,86	
503.12.12.119.S	SK 50	AD/B	M12	119	12,5	21	100	2,83	
503.12.12.169.S	SK 50	AD/B	M12	169	12,5	21	150	2,96	
503.12.16.119.S	SK 50	AD/B	M16	119	17	29	100	3,06	
503.12.16.169.S	SK 50	AD/B	M16	169	17	29	150	3,33	

FORM AD/B

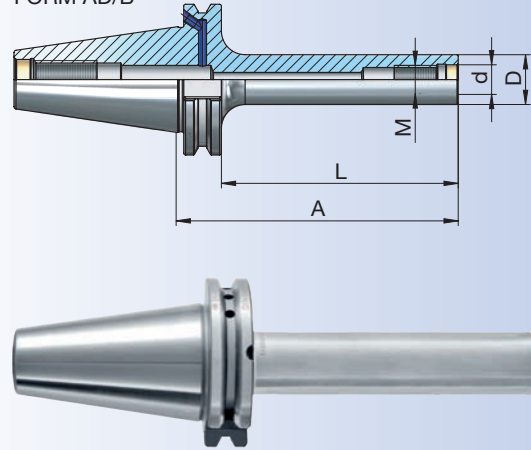

Empfohlene Anzugsmomente Recommended tightening torques Torques de serrage recommandés Önerilen sıkma torku

M6	10 Nm
M8	25 Nm
M10	40 Nm
M12	60 Nm
M16	80 Nm

Zubehör / Accessories / Accessoires / Yedekler



Verlängerungen für Einschraubfräser
Extensions for milling cutter arbors
Extension pour vis-sur-type coupeurs de fraisage
Vidalı tip frezeler için ara adaptör



Reduzierungen für Einschraubfräser
Reducing for milling cutter arbors
Extension pour vis-sur-type coupeurs de fraisage
Vidalı tip frezeler için ara adaptör



Bohrerhalter für Wendepplattenbohrer E1

Boring holder for drill with indexable insert form E1

Porte foret pour foret à plaquettes réversible forme E1

Takma uçlu drill tutucu E1 Formu

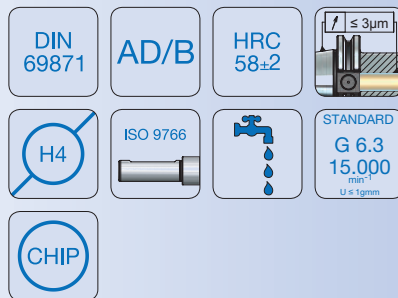

Bestell-Nr. Order Nr. Reference Sipariş Nr.	SK	Form	d	A	D	L2	Kg	Euro
403.51.20.65	SK 40	AD/B	20	65	40	56	1,10	
403.51.25.70	SK 40	AD/B	25	70	45	61,5	1,17	
403.51.32.75	SK 40	AD/B	32	75	52	66,5	1,27	
403.51.40.115	SK 40	AD/B	40	115	63	73	2,32	

503.51.20.70	SK 50	AD/B	20	70	40	54	2,83	
503.51.25.70	SK 50	AD/B	25	70	45	59	2,88	
503.51.32.70	SK 50	AD/B	32	70	52	67,5	2,87	
503.51.40.80	SK 50	AD/B	40	80	63	77	3,07	

FORM AD/B

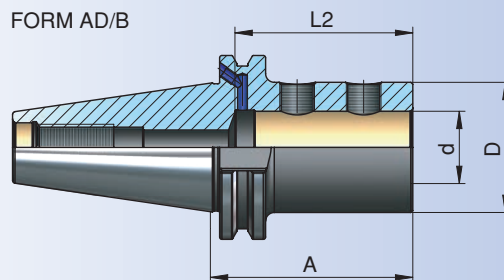

Zubehör / Accessories / Accessoires / Yedekler

DIN 913



Spannschrauben
Clamping screw
Vis de serrage
Sıkma civatası

10.39 - 10.40

Bohrfutteraufnahme

Drill chuck adaptor

Arbre pour mandrin de perçage

Mandren malafası

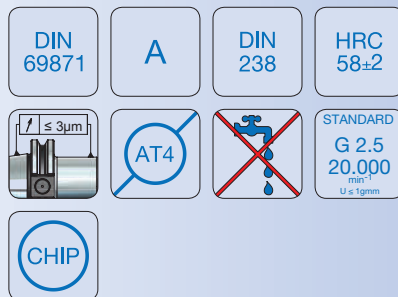

Bestell-Nr. Order Nr. Reference Sipariş Nr.	SK	Form	D1	A	L1	Kg	Euro
302.14.12.40	SK 30	A	B12	40	18,5	0,48	
302.14.16.41	SK 30	A	B16	41	24	0,51	

402.14.12.24	SK 40	A	B12	24	18,5	0,85	
402.14.16.26	SK 40	A	B16	26	24	0,87	
402.14.18.42	SK 40	A	B18	42	32	1,07	

502.14.16.26	SK 50	A	B16	26	24	2,69	
502.14.18.26	SK 50	A	B18	26	32	2,72	

FORM A

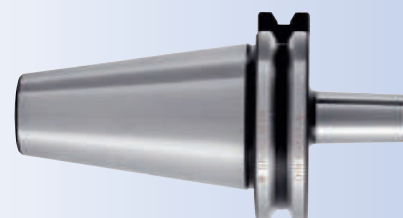
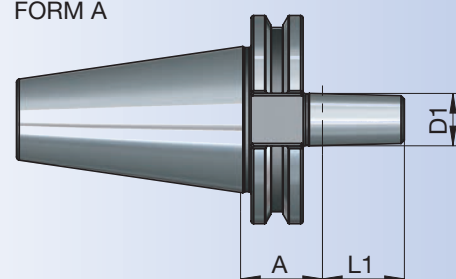

Zubehör / Accessories / Accessoires / Yedekler



Bohrfutter
Drill chuck
Mandrin de perçage à serrage rapide
Mandren

10.49



NC - Bohrfutter für Rechts - und Linkslauf

NC-Drill chucks for left and right rotation

Mandrin de perçage CNC pour rotation gauche-droite

NC tipi mandren malafası komple sağ ve sol dönüşlü

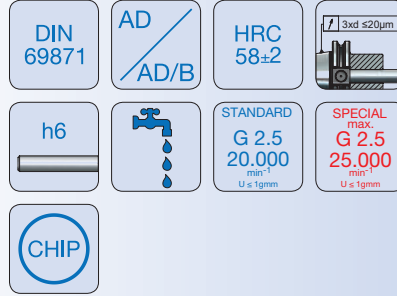

Bestell-Nr. Order Nr. Reference Sipariş Nr.	SK	Form	Spannbereich Capacity Capacité Kapasite	A	D	A1 Max.	Kg	Euro
302.15.08.70	SK 30	AD	0,5 - 8	70	36	73	1,06	
302.15.13.111	SK 30	AD	1,0 - 13	111	50	119	1,51	
402.15.08.70	SK 40	AD	0,5 - 8	70	36	73	1,13	
403.15.08.70	SK 40	AD/B	0,5 - 8	70	36	73	1,17	
402.15.13.90	SK 40	AD	1,0 - 13	90	50	98	1,65	
403.15.13.90	SK 40	AD/B	1,0 - 13	90	50	98	1,61	
402.15.16.95	SK 40	AD	3,0 - 16	95	57	100	1,88	
403.15.16.95	SK 40	AD/B	3,0 - 16	95	57	100	1,84	
502.15.13.90	SK 50	AD	1,0 - 13	90	50	98	3,43	
503.15.13.90	SK 50	AD/B	1,0 - 13	90	50	98	3,47	
502.15.16.95	SK 50	AD	3,0 - 16	95	57	100	3,68	
503.15.16.95	SK 50	AD/B	3,0 - 16	95	57	100	3,71	

FORM AD

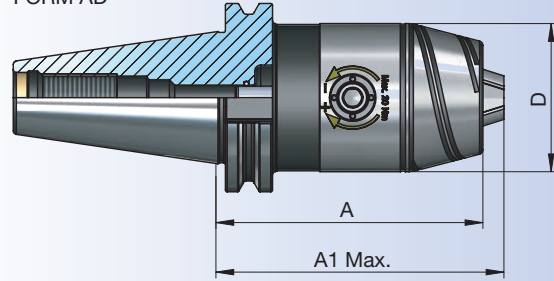

FORM AD/B

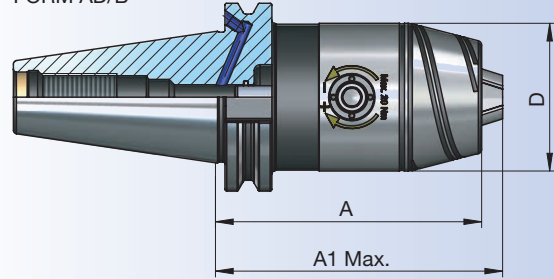

Zubehör / Accessories / Accessoires / Yedekler



10.55-10.57

Ersatzteile
Spare Parts
Pièce de rechange
Yedek parçalar



10.49

Spannschlüssel
Wrench
Clé de serrage
Sıkma anahtarı



11.06



Gewindeschneid - Schnellwechselfutter mit Längenausgleich auf Druck und Zug

Quick-change tapping chucks with length compensation

Appareil à tarauder avec compensation longitudinale

Kılavuz çekme başlığı giriş ve çıkış kompanzeli

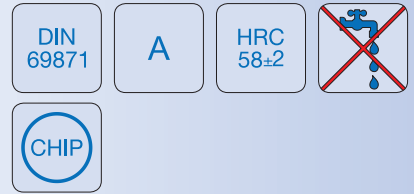

Bestell-Nr. Order Nr. Reference Sipariş Nr.	SK	Form	Spannbereich Capacity Capacité Kapasite	d	A	D	C	T	Kg	Euro
302.16.12.66	SK 30	A	M2-M14	19	66	36,5	7	7	0,58	
302.16.20.99	SK 30	A	M5-M24	31	99	53,5	12	12	1,25	
402.16.12.64	SK 40	A	M2-M14	19	64	36,5	7	7	1,01	
402.16.20.97	SK 40	A	M5-M24	31	97	53,5	12	12	1,66	
402.16.36.136	SK 40	A	M14-M36	48	136	78	17,5	17,5	3,01	
502.16.12.62	SK 50	A	M2-M14	19	62	36,5	7	7	2,76	
502.16.20.85	SK 50	A	M5-M24	31	85	53,5	12	12	3,21	
502.16.36.138	SK 50	A	M14-M36	48	138	78	17,5	17,5	5,21	

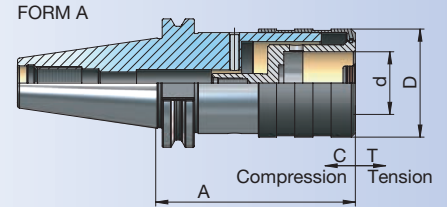

Ausführung : Mit Kugelführungsbuchse

Version : With ball retainer

Version : Comprenant douille de glissière à bille

Teknik özelliği : Bilya Kafesli

Gewindeschneid - Schnellwechselfutter ohne Längenausgleich auf Druck und Zug

Quick-change tapping chucks without length compensation

Appareil à tarauder sans compensation longitudinale

Kılavuz çekme başlığı sabit

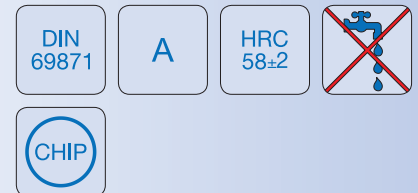

Bestell-Nr. Order Nr. Reference Sipariş Nr.	SK	Form	Spannbereich Capacity Capacité Kapasite	d	A	D	Kg	Euro
302.16.12.1.65	SK 30	A	M2-M14	19	65	38	0,77	
302.16.20.1.93	SK 30	A	M5-M24	31	93	52	1,14	
402.16.12.1.62	SK 40	A	M2-M14	19	62	38	1,02	
402.16.20.1.95	SK 40	A	M5-M24	31	95	52	1,56	
402.16.36.1.137	SK 40	A	M14-M36	48	137	78	3,01	
502.16.12.1.60	SK 50	A	M2-M14	19	60	38	2,82	
502.16.20.1.85	SK 50	A	M5-M24	31	85	52	3,19	
502.16.36.1.117	SK 50	A	M14-M36	48	117	78	4,69	

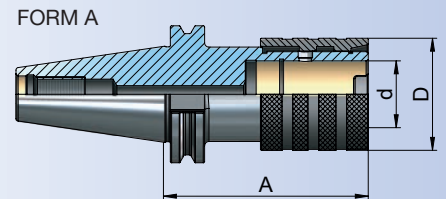

Zubehör / Accessories / Accessoires / Yedekler



Schnellwechseleinsätze
Tapping collets
Douilles de taraudage
Kılavuz tutucu



Rohlinge zur Anfertigung von Sonderwerkzeugen

Boring bar blanks for the production of special tools

Barre d'alésage pour la fabrication d'outils spéciaux

Özel takım yapma amaçlı yarı mamul

DIN
69871

A

HRC
52±2



CHIP

Bestell-Nr. Order Nr. Reference Sipariş Nr.	SK	Form	D	A	Kg	Euro
402.17.63.250	SK 40	A	63	250	6,29	
502.17.97.315	SK 50	A	97	315	19,40	

FORM A

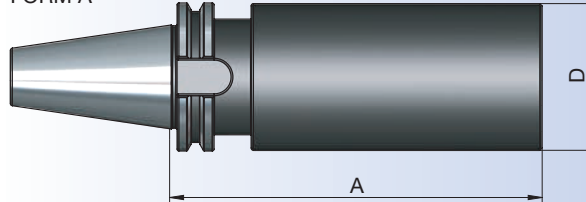

Ausführung : Steilkegel und Bund gehärtet (52±2 HRC) und geschliffen, Schaft weich zur weiteren Bearbeitung.

Version : Cone and flange hardened (52±2 HRC) and grinded. Soft body for later processing.

Version : Cône et collerette durcir (52±2 HRC) et rectifiés. Corps doux pour un usinage ultérieur.

Teknik özelliği : Konik ve Flanş kısmı sertleştirilmiş (52±2 HRC) ve taşlanmıştır. Bara kısmı işlenebilir yumuşaklıktadır.

Kontrolldorne

Test arbors

Mandrins de contrôle

Fener mili kontrol mastarı

DIN
69871

A

HRC
58±2



Bestell-Nr. Order Nr. Reference Sipariş Nr.	SK	Form	D	A	Kg	Euro
302.18.32.200	SK 30	A	32	200	1,41	
402.18.40.300	SK 40	A	40	300	3,39	
502.18.50.300	SK 50	A	50	300	6,33	

FORM A

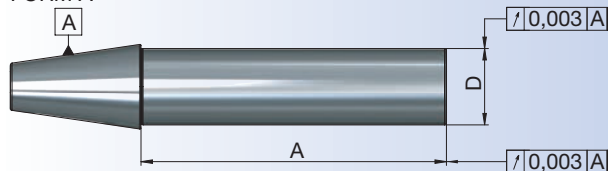

Verwendung : Zur Abnahme von Werkzeugmaschinen gemäß ISO-Empfehlung R230

Application : For acceptance tests of machine tools in accordance with ISO-recommendation R230

Application : Pour la recette technique des machines conforme recommandation ISO R230

Açıklama : Tezgahları devreye alırken ISO Normu R230 sisteminde uygunluğunu kontrol etmek için



Schrumpffutter zum Spannen von HM Werkzeugschäften

Shrink chuck for mounting of solid carbide cutters

Mandrin de frettage pour le serrage des queue d'outils carbure

Isıtmalı takım tutucular şaftı karbür olan takımlar için

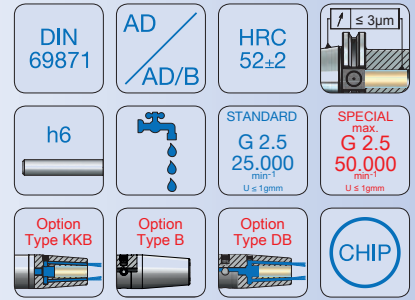

Bestell-Nr. Order Nr. Reference Sipariş Nr.	SK	Form	d	A	D	D1	L2	Kg	Euro
302.25.03.80	SK 30	AD	3	80	10	16	14	0,44	
302.25.04.80	SK 30	AD	4	80	12	20	17	0,47	
302.25.05.80	SK 30	AD	5	80	12	21,5	20	0,47	
302.25.06.80	SK 30	AD	6	80	21	27	36	0,59	
302.25.08.80	SK 30	AD	8	80	21	27	36	0,58	
302.25.10.80	SK 30	AD	10	80	24	32	42	0,65	
302.25.12.80	SK 30	AD	12	80	24	32	47	0,63	
302.25.14.80	SK 30	AD	14	80	27	34	47	0,68	
302.25.16.80	SK 30	AD	16	80	27	34	50	0,66	
302.25.18.80	SK 30	AD	18	80	33	42	50	0,80	
302.25.20.80	SK 30	AD	20	80	33	42	52	0,76	

FORM AD

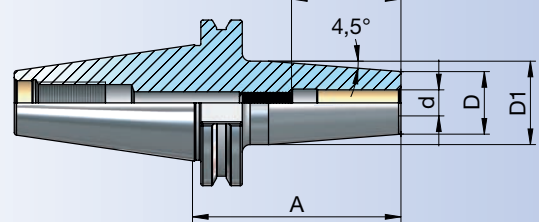

FORM AD/B

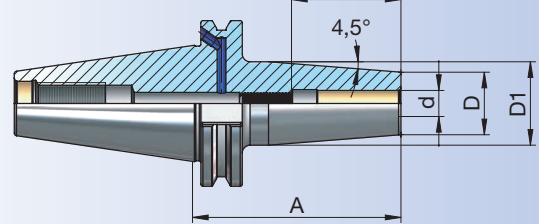

403.25.03.80	SK 40	AD/B	3	80	10	16	14	0,85	
*403.25.03.120	SK 40	AD/B	3	120	10	16	14	0,91	
*403.25.03.160	SK 40	AD/B	3	160	10	16	14	0,97	
new *403.25.03.200	SK 40	AD/B	3	200	10	16	14	1,03	
403.25.04.80	SK 40	AD/B	4	80	12	20	17	0,88	
*403.25.04.120	SK 40	AD/B	4	120	12	20	17	0,98	
*403.25.04.160	SK 40	AD/B	4	160	12	20	17	1,07	
new *403.25.04.200	SK 40	AD/B	4	200	12	20	17	1,17	
403.25.05.80	SK 40	AD/B	5	80	12	21,5	20	0,89	
*403.25.05.120	SK 40	AD/B	5	120	12	22	20	1,00	
*403.25.05.160	SK 40	AD/B	5	160	12	22	20	1,11	
new *403.25.05.200	SK 40	AD/B	5	200	12	22	20	1,22	
403.25.06.80	SK 40	AD/B	6	80	21	27	36	1,03	
403.25.06.120	SK 40	AD/B	6	120	21	27	36	1,19	
403.25.06.160	SK 40	AD/B	6	160	21	27	36	1,35	
new *403.25.06.200	SK 40	AD/B	6	200	21	27	36	1,52	
403.25.08.80	SK 40	AD/B	8	80	21	27	36	1,02	
403.25.08.120	SK 40	AD/B	8	120	21	27	36	1,18	
403.25.08.160	SK 40	AD/B	8	160	21	27	36	1,35	
new *403.25.08.200	SK 40	AD/B	8	200	21	27	36	1,53	



* Einstellschraube nicht enthalten
* Does not include adjusting screw
* Ne comprend pas la vis de réglage
* Dayama civatası içermez

Zubehör / Accessories / Accessoires / Yedekler

DIN 916		Einstellschraube Adjusting screw Vis de réglage Dayama civatası	
10.41-10.43			
			11.08



Schrumpffutter zum Spannen von HM Werkzeugschäften

Shrink chuck for mounting of solid carbide cutters

Mandrin de frettage pour le serrage des queue d'outils carbure

Isıtmalı takım tutucular şaftı karbür olan takımlar için

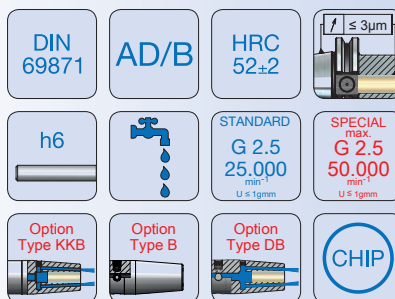

Bestell-Nr. Order Nr. Reference Sipariş Nr.	SK	Form	d	A	D	D1	L2	Kg	Euro
403.25.10.80	SK 40	AD/B	10	80	24	32	42	1,09	
403.25.10.120	SK 40	AD/B	10	120	24	32	42	1,32	
403.25.10.160	SK 40	AD/B	10	160	24	32	42	1,56	
new 403.25.10.200	SK 40	AD/B	10	200	24	32	42	1,80	
403.25.12.80	SK 40	AD/B	12	80	24	32	47	1,06	
403.25.12.120	SK 40	AD/B	12	120	24	32	47	1,27	
403.25.12.160	SK 40	AD/B	12	160	24	32	47	1,49	
new 403.25.12.200	SK 40	AD/B	12	200	24	32	47	1,71	
403.25.14.80	SK 40	AD/B	14	80	27	34	47	1,10	
403.25.14.120	SK 40	AD/B	14	120	27	34	47	1,35	
403.25.14.160	SK 40	AD/B	14	160	27	34	47	1,60	
new 403.25.14.200	SK 40	AD/B	14	200	27	34	47	1,86	
403.25.16.80	SK 40	AD/B	16	80	27	34	50	1,08	
403.25.16.120	SK 40	AD/B	16	120	27	34	50	1,33	
403.25.16.160	SK 40	AD/B	16	160	27	34	50	1,58	
new 403.25.16.200	SK 40	AD/B	16	200	27	34	50	1,84	
403.25.18.80	SK 40	AD/B	18	80	33	42	50	1,23	
403.25.18.120	SK 40	AD/B	18	120	33	42	50	1,62	
403.25.18.160	SK 40	AD/B	18	160	33	42	50	2,02	
new 403.25.18.200	SK 40	AD/B	18	200	33	42	50	2,42	
403.25.20.80	SK 40	AD/B	20	80	33	42	52	1,20	
403.25.20.120	SK 40	AD/B	20	120	33	42	52	1,60	
403.25.20.160	SK 40	AD/B	20	160	33	42	52	1,99	
new 403.25.20.200	SK 40	AD/B	20	200	33	42	52	2,38	
403.25.25.100	SK 40	AD/B	25	100	44	53	58	1,75	
403.25.25.120	SK 40	AD/B	25	120	44	53	58	2,08	
403.25.25.160	SK 40	AD/B	25	160	44	53	58	2,73	
new 403.25.25.200	SK 40	AD/B	25	200	44	53	58	3,38	
403.25.32.100	SK 40	AD/B	32	100	44	53	62	1,59	
403.25.32.120	SK 40	AD/B	32	120	44	53	62	1,92	
403.25.32.160	SK 40	AD/B	32	160	44	53	62	2,57	
new 403.25.32.200	SK 40	AD/B	32	200	44	53	62	3,20	

FORM AD/B

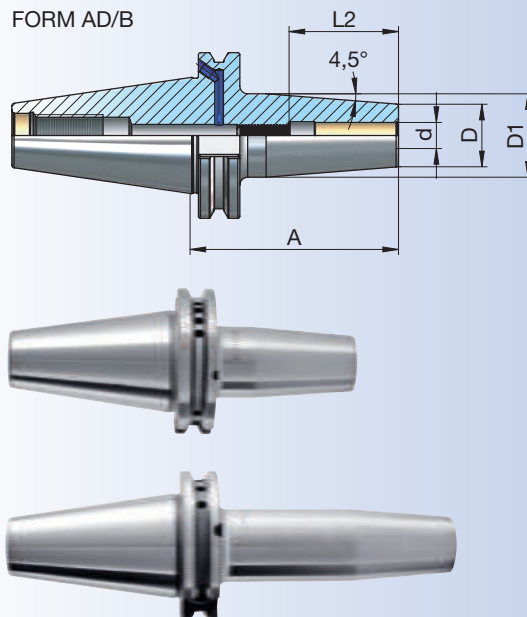

Zubehör / Accessories / Accessoires / Yedekler

DIN 916	 Einstellschraube Adjusting screw Vis de réglage Dayama civatası	 11.08
10.41-10.43		



Schrumpffutter zum Spannen von HM Werkzeugschäften

Shrink chuck for mounting of solid carbide cutters

Mandrin de frettage pour le serrage des queue d'outils carbure

Isıtmalı takım tutucular şaftı karbür olan takımlar için

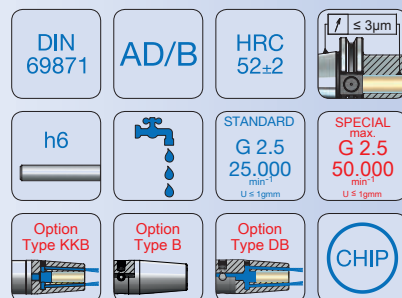

Bestell-Nr. Order Nr. Reference Sipariş Nr.	SK	Form	d	A	D	D1	L2	Kg	Euro
503.25.03.80	SK 50	AD/B	3	80	10	16	14	2,66	
*503.25.03.120	SK 50	AD/B	3	120	10	16	14	2,72	
*503.25.03.160	SK 50	AD/B	3	160	10	16	14	2,77	
new *503.25.03.200	SK 50	AD/B	3	200	10	16	14	2,83	
503.25.04.80	SK 50	AD/B	4	80	12	20	17	2,69	
*503.25.04.120	SK 50	AD/B	4	120	12	20	17	2,78	
*503.25.04.160	SK 50	AD/B	4	160	12	20	17	2,88	
new *503.25.04.200	SK 50	AD/B	4	200	12	20	17	2,97	
503.25.05.80	SK 50	AD/B	5	80	12	21,5	20	2,69	
*503.25.05.120	SK 50	AD/B	5	120	12	22	20	2,80	
*503.25.05.160	SK 50	AD/B	5	160	12	22	20	2,91	
new *503.25.05.200	SK 50	AD/B	5	200	12	22	20	3,02	
503.25.06.80	SK 50	AD/B	6	80	21	27	36	2,84	
503.25.06.120	SK 50	AD/B	6	120	21	27	36	3,00	
503.25.06.160	SK 50	AD/B	6	160	21	27	36	3,16	
new 503.25.06.200	SK 50	AD/B	6	200	21	27	36	3,33	
503.25.08.80	SK 50	AD/B	8	80	21	27	36	2,83	
503.25.08.120	SK 50	AD/B	8	120	21	27	36	2,99	
503.25.08.160	SK 50	AD/B	8	160	21	27	36	3,16	
new 503.25.08.200	SK 50	AD/B	8	200	21	27	36	3,32	
503.25.10.80	SK 50	AD/B	10	80	24	32	42	2,89	
503.25.10.120	SK 50	AD/B	10	120	24	32	42	3,13	
503.25.10.160	SK 50	AD/B	10	160	24	32	42	3,36	
new 503.25.10.200	SK 50	AD/B	10	200	24	32	42	3,59	
503.25.12.80	SK 50	AD/B	12	80	24	32	47	2,86	
503.25.12.120	SK 50	AD/B	12	120	24	32	47	3,07	
503.25.12.160	SK 50	AD/B	12	160	24	32	47	3,29	
new 503.25.12.200	SK 50	AD/B	12	200	24	32	47	3,51	

FORM AD/B

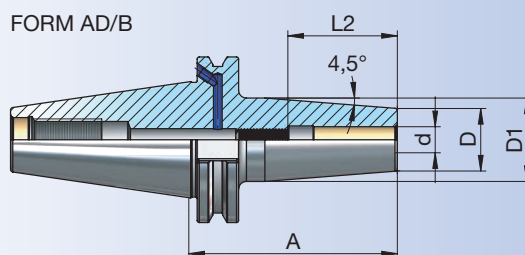

- * Einstellschraube nicht enthalten
- * Does not include adjusting screw
- * Ne comprend pas la vis de réglage
- * Dayama civatası içermez

Zubehör / Accessories / Accessoires / Yedekler



Einstellschraube
Adjusting screw
Vis de réglage
Dayama civatası



11.08



Schrumpffutter zum Spannen von HM Werkzeugschäften

Shrink chuck for mounting of solid carbide cutters

Mandrin de frettage pour le serrage des queue d'outils carbure

Isıtmalı takım tutucular shaftı karbür olan takımlar için

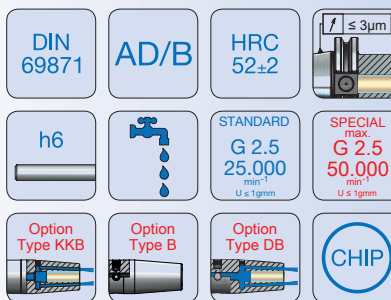

Bestell-Nr. Order Nr. Reference Sipariş Nr.	SK	Form	d	A	D	D1	L2	Kg	Euro
503.25.14.80	SK 50	AD/B	14	80	27	34	47	2,91	
503.25.14.120	SK 50	AD/B	14	120	27	34	47	3,15	
503.25.14.160	SK 50	AD/B	14	160	27	34	47	3,40	
new 503.25.14.200	SK 50	AD/B	14	200	27	34	47	3,64	
503.25.16.80	SK 50	AD/B	16	80	27	34	50	2,89	
503.25.16.120	SK 50	AD/B	16	120	27	34	50	3,13	
503.25.16.160	SK 50	AD/B	16	160	27	34	50	3,38	
new 503.25.16.200	SK 50	AD/B	16	200	27	34	50	3,63	
503.25.18.80	SK 50	AD/B	18	80	33	42	50	3,03	
503.25.18.120	SK 50	AD/B	18	120	33	42	50	3,43	
503.25.18.160	SK 50	AD/B	18	160	33	42	50	3,83	
new 503.25.18.200	SK 50	AD/B	18	200	33	42	50	4,24	
503.25.20.80	SK 50	AD/B	20	80	33	42	52	3,00	
503.25.20.120	SK 50	AD/B	20	120	33	42	52	3,40	
503.25.20.160	SK 50	AD/B	20	160	33	42	52	3,80	
new 503.25.20.200	SK 50	AD/B	20	200	33	42	52	4,22	
503.25.25.100	SK 50	AD/B	25	100	44	53	58	3,59	
503.25.25.120	SK 50	AD/B	25	120	44	53	58	3,92	
503.25.25.160	SK 50	AD/B	25	160	44	53	58	4,58	
new 503.25.25.200	SK 50	AD/B	25	200	44	53	58	5,26	
503.25.32.100	SK 50	AD/B	32	100	44	53	62	3,43	
503.25.32.120	SK 50	AD/B	32	120	44	53	62	3,76	
503.25.32.160	SK 50	AD/B	32	160	44	53	62	4,41	
new 503.25.32.200	SK 50	AD/B	32	200	44	53	62	5,02	

FORM AD/B

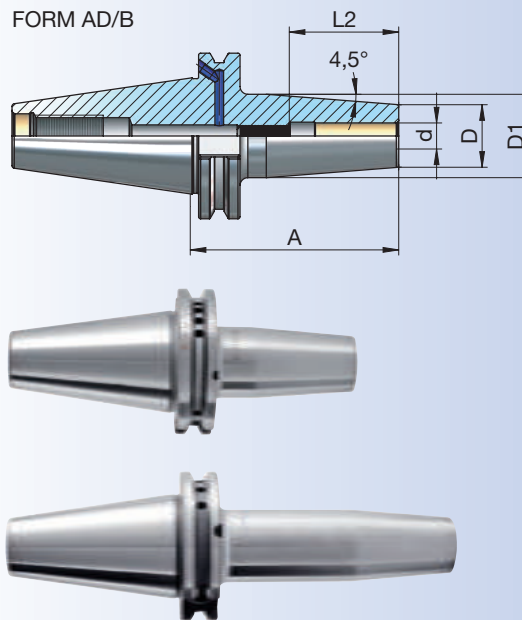

Zubehör / Accessories / Accessoires / Yedekler

DIN 916  10.41-10.43	Einstellschraube Adjusting screw Vis de réglage Dayama civatası	 11.08
---------------------------------------------------------------------------------------------------------------	--------------------------------------------------------------------------	----------------------------------------------------------------------------------------------



Schrumpffutter - schlanke Ausführung für HM Werkzeugschäften

Shrink chucks - slimline design for solid carbide cutters

Mandrins de frettage - design mince four queue d'outils carbure

İnce cidarlı ısıtılmalı takım tutucular şaftı karbür olan takımlar için

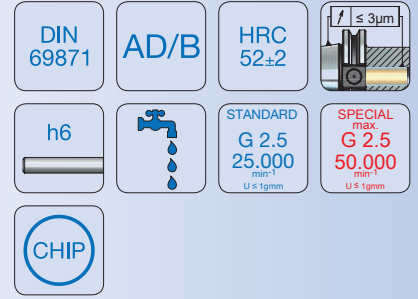

Bestell-Nr. Order Nr. Reference Sipariş Nr.	SK	Form	d	A	D	D1	L2	Kg	Euro
403.25.03.80.S	SK 40	AD/B	3	80	9	14	14	0,84	
*403.25.03.120.S	SK 40	AD/B	3	120	9	18	14	0,91	
403.25.04.80.S	SK 40	AD/B	4	80	10	15	17	0,84	
*403.25.04.120.S	SK 40	AD/B	4	120	10	19	17	0,92	
403.25.05.80.S	SK 40	AD/B	5	80	11	16	20	0,85	
*403.25.05.120.S	SK 40	AD/B	5	120	11	20	20	0,94	
403.25.06.80.S	SK 40	AD/B	6	80	12	17	36	0,88	
403.25.06.120.S	SK 40	AD/B	6	120	12	21	36	0,97	
403.25.06.160.S	SK 40	AD/B	6	160	12	25	36	1,10	
403.25.08.80.S	SK 40	AD/B	8	80	14	19	36	0,90	
403.25.08.120.S	SK 40	AD/B	8	120	14	23	36	1,00	
403.25.08.160.S	SK 40	AD/B	8	160	14	27	36	1,16	
403.25.10.80.S	SK 40	AD/B	10	80	16	21	42	0,91	
403.25.10.120.S	SK 40	AD/B	10	120	16	25	42	1,04	
403.25.10.160.S	SK 40	AD/B	10	160	16	29	42	1,23	
403.25.12.80.S	SK 40	AD/B	12	80	18	23	47	0,91	
403.25.12.120.S	SK 40	AD/B	12	120	18	27	47	1,05	
403.25.12.160.S	SK 40	AD/B	12	160	18	31	47	1,24	

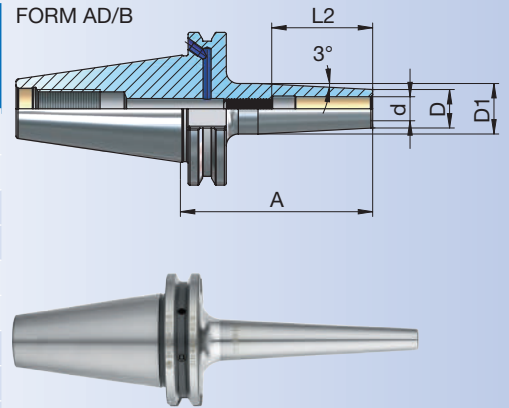

503.25.03.80.S	SK 50	AD/B	3	80	9	14	14	2,64	
*503.25.03.120.S	SK 50	AD/B	3	120	9	18	14	2,71	
503.25.04.80.S	SK 50	AD/B	4	80	10	15	17	2,65	
*503.25.04.120.S	SK 50	AD/B	4	120	10	19	17	2,73	
503.25.05.80.S	SK 50	AD/B	5	80	11	16	20	2,66	
*503.25.05.120.S	SK 50	AD/B	5	120	11	20	20	2,74	
503.25.06.80.S	SK 50	AD/B	6	80	12	17	36	2,69	
503.25.06.120.S	SK 50	AD/B	6	120	12	21	36	2,77	
503.25.06.160.S	SK 50	AD/B	6	160	12	25	36	2,90	
503.25.08.80.S	SK 50	AD/B	8	80	14	19	36	2,71	
503.25.08.120.S	SK 50	AD/B	8	120	14	23	36	2,81	
503.25.08.160.S	SK 50	AD/B	8	160	14	27	36	2,97	
503.25.10.80.S	SK 50	AD/B	10	80	16	21	42	2,72	
503.25.10.120.S	SK 50	AD/B	10	120	16	25	42	2,85	
503.25.10.160.S	SK 50	AD/B	10	160	16	29	42	3,03	
503.25.12.80.S	SK 50	AD/B	12	80	18	23	47	2,72	
503.25.12.120.S	SK 50	AD/B	12	120	18	27	47	2,85	
503.25.12.160.S	SK 50	AD/B	12	160	18	31	47	3,05	

- * Einstellschraube nicht enthalten
- * Does not include adjusting screw
- * Ne comprend pas la vis de réglage
- * Dayama civatası içermez

Zubehör / Accessories / Accessoires / Yedekler





Hydro - Dehnspanfutter

Hydraulic expansions chuck

Mandrins expansibles hydrauliques

Hidrolik takım tutucular

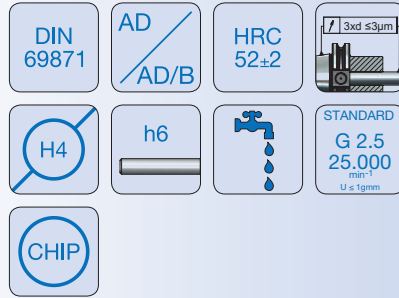

Bestell-Nr. Order Nr. Reference Sipariş Nr.	SK	Form	d	A	D	D1	L1	L2	Kg	Euro
302.65.12.90	SK 30	AD	12	90	32	49,5	36	46	0,90	
302.65.20.100	SK 30	AD	20	100	42	49,5	46	57	1,09	
403.65.06.80	SK 40	AD/B	6	80	26	49,5	40	37	1,16	
403.65.08.80	SK 40	AD/B	8	80	28	49,5	40	37	1,18	
403.65.10.80	SK 40	AD/B	10	80	30	49,5	40	41	1,19	
403.65.12.80	SK 40	AD/B	12	80	32	49,5	40	46	1,21	
403.65.14.80	SK 40	AD/B	14	80	34	49,5	40	46	1,22	
403.65.16.80	SK 40	AD/B	16	80	38	49,5	46	49	1,27	
403.65.18.80	SK 40	AD/B	18	80	40	49,5	46	49	1,27	
403.65.20.80	SK 40	AD/B	20	80	42	49,5	46	57	1,29	
403.65.25.95	SK 40	AD/B	25	95	49,5	55	76	57	1,78	
403.65.32.95	SK 40	AD/B	32	95	56	63	76	57	1,91	
503.65.06.80	SK 50	AD/B	6	80	26	49,5	40	37	2,83	
503.65.08.80	SK 50	AD/B	8	80	28	49,5	40	37	2,93	
503.65.10.80	SK 50	AD/B	10	80	30	49,5	40	41	2,81	
503.65.12.80	SK 50	AD/B	12	80	32	49,5	40	46	2,88	
503.65.14.80	SK 50	AD/B	14	80	34	49,5	40	46	2,88	
503.65.16.80	SK 50	AD/B	16	80	38	49,5	46	49	2,88	
503.65.18.80	SK 50	AD/B	18	80	40	49,5	46	49	2,93	
503.65.20.80	SK 50	AD/B	20	80	42	49,5	46	57	2,98	
503.65.25.100	SK 50	AD/B	25	100	55	60	55	57	3,65	
503.65.32.100	SK 50	AD/B	32	100	63	70	55	57	4,03	

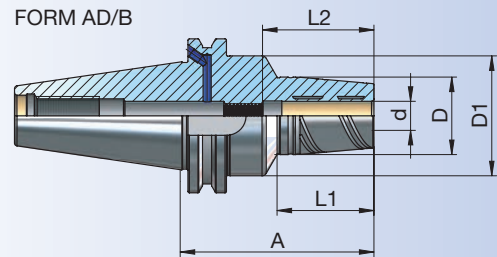
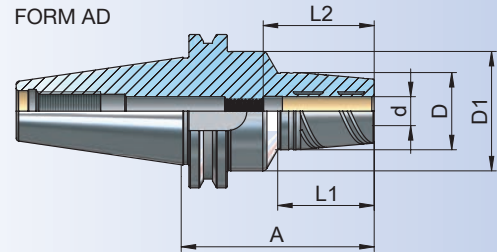

Zubehör / Accessories / Accessoires / Yedekler



Reduzierungen
Reducing arbor
Douille de réduction
Pens



DIN 916
Einstellschraube
Adjusting screw
Vis de réglage
Dayama civatası



Spannschlüssel
Wrench
Clé de serrage
Sıkma anahtarı



Büchsenzieher für Reduzierungen
Sleeve remover for reducing arbor
Clé étirage pour douilles
Hidrolik Takım Pensi Çıkarma Anahtarı



11.10



Hydro - Dehnspannfutter lange Ausführung

Hydraulic expansions chuck, long

Mandrins expansibles hydrauliques, longue

Hidrolik takım tutucular, uzun

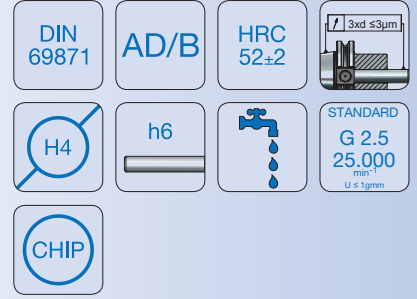

Bestell-Nr. Order Nr. Reference Sipariş Nr.	SK	Form	d	A	D	D1	L1	L2	Kg	Euro
403.65.06.110	SK 40	AD/B	6	110	26	49,5	40	37	1,65	
403.65.08.110	SK 40	AD/B	8	110	28	49,5	40	37	1,64	
403.65.10.110	SK 40	AD/B	10	110	30	49,5	40	41	1,63	
403.65.12.110	SK 40	AD/B	12	110	32	49,5	40	46	1,65	
403.65.14.110	SK 40	AD/B	14	110	34	49,5	40	46	1,63	
403.65.16.110	SK 40	AD/B	16	110	38	49,5	46	49	1,66	
403.65.18.110	SK 40	AD/B	18	110	40	49,5	46	49	1,91	
403.65.20.110	SK 40	AD/B	20	110	42	49,5	46	51	1,70	
403.65.25.110	SK 40	AD/B	25	110	49,5	55	91	57	2,03	
403.65.32.110	SK 40	AD/B	32	110	56	63	91	61	2,24	

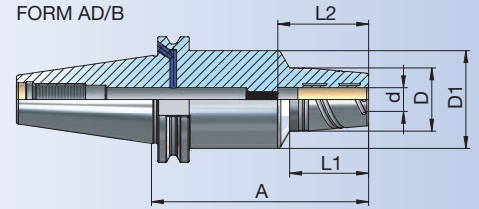

503.65.06.110	SK 50	AD/B	6	110	26	49,5	40	37	3,41	
503.65.08.110	SK 50	AD/B	8	110	28	49,5	40	37	3,49	
503.65.10.110	SK 50	AD/B	10	110	30	49,5	40	41	3,56	
503.65.12.110	SK 50	AD/B	12	110	32	49,5	40	46	3,43	
503.65.14.110	SK 50	AD/B	14	110	34	49,5	40	46	3,47	
503.65.16.110	SK 50	AD/B	16	110	38	49,5	46	49	3,40	
503.65.18.110	SK 50	AD/B	18	110	40	49,5	46	49	3,53	
503.65.20.110	SK 50	AD/B	20	110	42	49,5	46	51	3,52	
503.65.25.120	SK 50	AD/B	25	120	55	60	55	57	4,23	
503.65.32.120	SK 50	AD/B	32	120	63	70	55	61	4,83	

Hydro - Dehnspannfutter schlanke Ausführung

Hydraulic expansions chuck, slimline design

Mandrins expansibles hydrauliques, design mince

Hidrolik takım tutucular, ince cidarlı

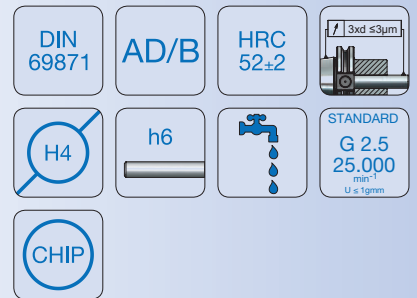

Bestell-Nr. Order Nr. Reference Sipariş Nr.	SK	Form	d	A	D	D1	L1	L2	Kg	Euro
403.65.12.110.S	SK 40	AD/B	12	110	25	49,5	60	46	1,35	
503.65.12.110.S	SK 50	AD/B	12	110	25	49,5	60	46	3,60	

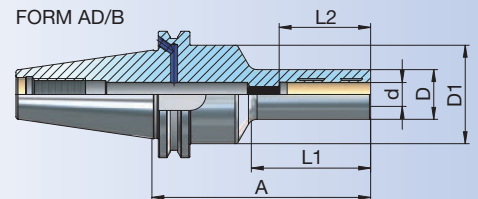

Zubehör / Accessories / Accessoires / Yedekler



Reduzierungen
Reducing arbor
Douille de réduction
Pens



DIN 916
Einstellschraube
Adjusting screw
Vis de réglage
Dayama civatası



Spannschlüssel
Wrench
Clé de serrage
Sıkma anahtarı



Büchsenzieher für Reduzierungen
Sleeve remover for reducing arbor
Clé étirage pour douilles
Hidrolik Takım Pensi Çıkarma Anahtarı





Hydro - Dehnspannfutter extra kurze Ausführung

Hydraulic expansions chuck extra, short

Mandrins expansibles hydrauliques extra, court

Hidrolik takım tutucu, ekstra kısa

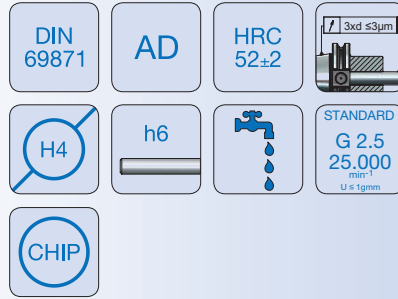

Bestell-Nr. Order Nr. Reference Sipariş Nr.	SK	Form	d	A	D	L2	Kg	Euro
402.65.20.24	SK 40	AD	20	24,6	49,5	51	0,74	

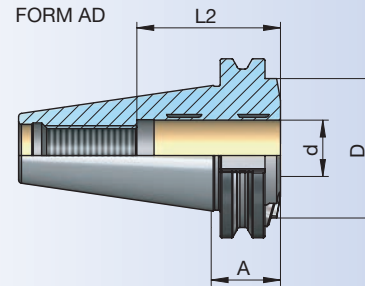

Zubehör / Accessories / Accessoires / Yedekler



Reduzierungen
Reducing arbor
Douille de réduction
Pens



Spannschlüssel
Wrench
Clé de serrage
Sıkma anahtar



Büchsenzieher für Reduzierungen
Sleeve remover for reducing arbor
Clé étréage pour douilles
Hidrolik Takım Pensi Çıkarma Anahtar

Hydro - Dehnspannfutter kurz /schwer

Hydraulic expansions chuck, short heavy

Mandrins expansibles hydrauliques, court lourd

Hidrolik takım tutucu, kısa rijit

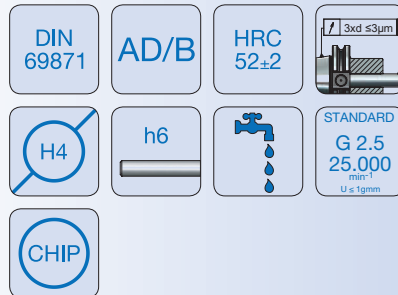

Bestell-Nr. Order Nr. Reference Sipariş Nr.	SK	Form	d	A	D	L2	Kg	Euro
403.65.20.64	SK 40	AD/B	20	64,5	49,5	51	1,27	

503.65.20.64	SK 50	AD/B	20	64,5	49,5	51	2,10	
503.65.32.81	SK 50	AD/B	32	81	72	61	3,95	

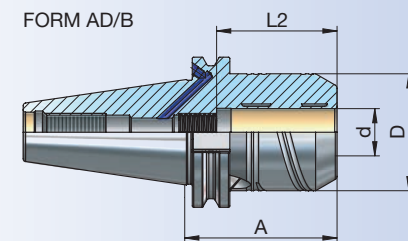

Zubehör / Accessories / Accessoires / Yedekler



Reduzierungen
Reducing arbor
Douille de réduction
Pens

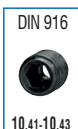

DIN 916
Einstellschraube
Adjusting screw
Vis de réglage
Dayama civatası



Spannschlüssel
Wrench
Clé de serrage
Sıkma anahtar



Büchsenzieher für Reduzierungen
Sleeve remover for reducing arbor
Clé étréage pour douilles
Hidrolik Takım Pensi Çıkarma Anahtar



11.10



Hydro-Dehnspannfuttersatz im Koffer

Hydraulic expansion chuck set in box

Mandrin expansibles hydraulique (set) dans coffre

Hidrolik tutucu seti plastik kutuda

DIN
69871

AD
AD/B

HRC
52±2



CHIP

Bestell-Nr. Order Nr. Reference Sipariş Nr.	SK	Form	Spannbereich Capacity Capacité Kapasite	Spannzangen Durchmesser Collet Diameter Pincas Diamètre Pens Çapı	Reduzierhulsen Reducing Réduction Pens Adedi	Kg	Euro
302.66.12.90	SK 30	AD	R12 (3-8)	3-4-5-6-8	5	1,75	
302.66.20.100	SK 30	AD	R20 (6-16)	6-8-10-12-16	5	2,12	
403.66.12.80	SK 40	AD/B	R12 (3-8)	3-4-5-6-8	5	2,06	
403.66.20.80	SK 40	AD/B	R20 (6-16)	6-8-10-12-16	5	2,30	
403.66.20.64	SK 40	AD/B	R20 (6-16)	6-8-10-12-16	5	2,30	
403.66.32.95	SK 40	AD/B	R32 (6-25)	6-8-10-12-16-20-25	7	4,35	
503.66.12.80	SK 50	AD/B	R12 (3-8)	3-4-5-6-8	5	4,14	
503.66.20.64	SK 50	AD/B	R20 (6-16)	6-8-10-12-16	5	2,70	
503.66.20.80	SK 50	AD/B	R20 (6-16)	6-8-10-12-16	5	4,38	
503.66.32.81	SK 50	AD/B	R32 (6-25)	6-8-10-12-16-20-25	7	6,59	
503.66.32.100	SK 50	AD/B	R32 (6-25)	6-8-10-12-16-20-25	7	6,67	

Lieferumfang : Spannfüter, inkl. Spannzangen mit Schlüssel
Included : Collet chuck with collets and wrench
Inclus : Mandrin avec pincas et clé
Teslim Şekli : Takım, pensleri ve anahtarıyla birlikte



Zubehör / Accessories / Accessoires / Yedekler



Reduzierungen
Reducing arbor
Douille de réduction
Pens



DIN 916
Einstellschraube
Adjusting screw
Vis de réglage
Dayama civatası



Spannschlüssel
Wrench
Clé de serrage
Sıkma anahtar



Büchsenzieher für Reduzierungen
Sleeve remover for reducing arbor
Clé étréage pour douilles
Hidrolik Takım Pensi Çıkarma Anahtar



11.10